

INSTALLATION INSTRUCTIONS

EQUIPMENT REQUIRED:

WIRING ACCESS LOCATION: SUV1, SUV2

DRILL BITS: 1" HOLE SAW FOR AXIOM ONLY

HITCH REQUIRES 5/8" PIN AND CLIP IF STABILIZING PIN IS NOT INSTALLED.

WRENCHES: (TIGHTEN ALL FASTENERS WITH TORQUE WRENCH) 19mm, 7/8, 15/16

(FOR MODELS WITH UNDER VEHICLE MOUNTED SPARE TIRE ONLY)

DO NOT EXCEED LOWER OF TOWING VEHICLE MFR'S RATINGS OR

HITCH TYPE ▼	MAX GROSS TRLR WT(LB)	MAX TONGUE WT(LB)
WEIGHT DISTRIBUTING	5000	500
WEIGHT CARRYING BALL MOUNT	3500	350

USED ONLY ON RODEO AND PASSPORT

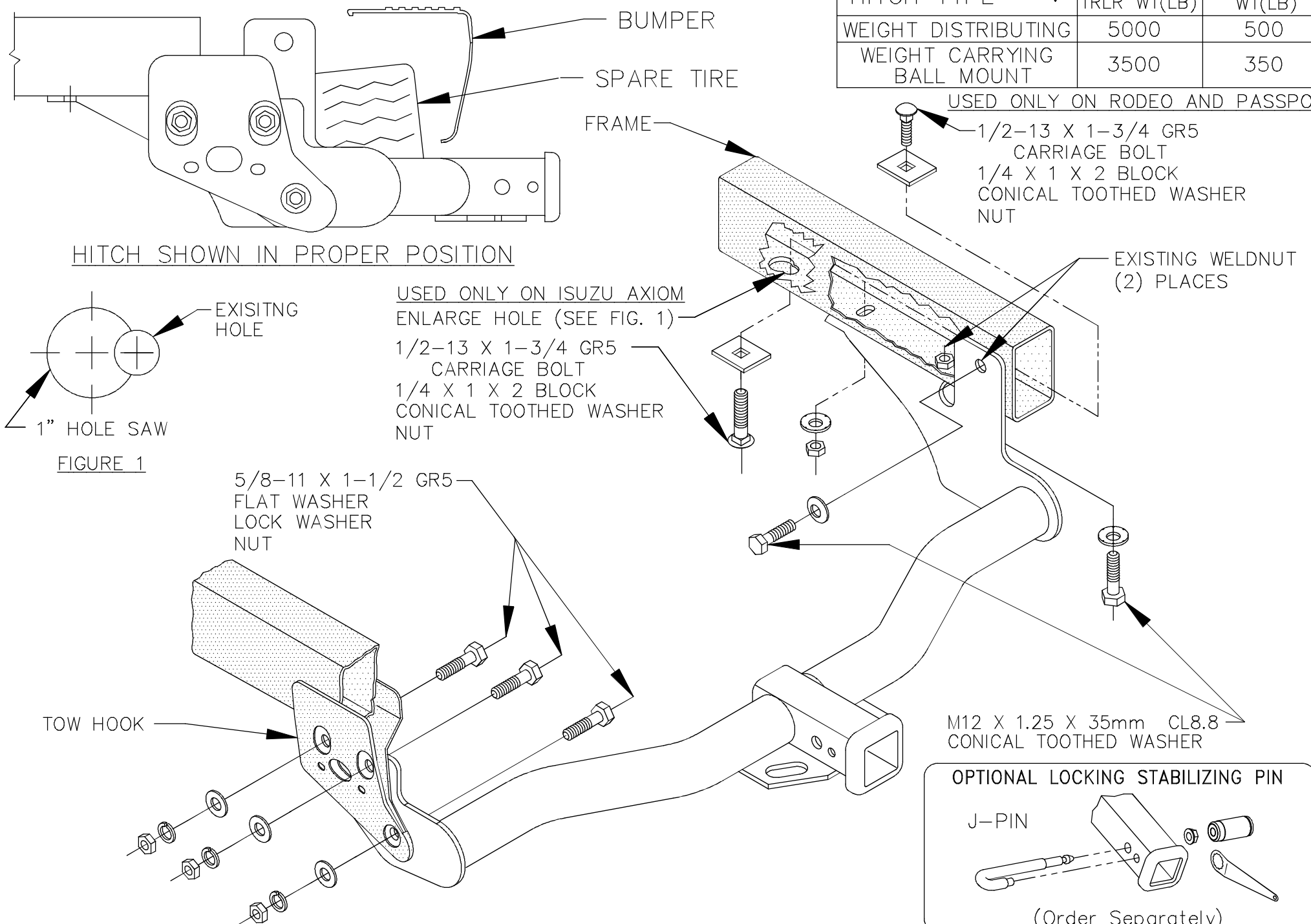

USED ONLY ON ISUZU AXIOM
ENLARGE HOLE (SEE FIG. 1)

1/2-13 X 1-3/4 GR5
CARRIAGE BOLT
1/4 X 1 X 2 BLOCK
CONICAL TOOTHED WASHER
NUT

5/8-11 X 1-1/2 GR5
FLAT WASHER
LOCK WASHER
NUT

M12 X 1.25 X 35mm CL8.8
CONICAL TOOTHED WASHER

OPTIONAL LOCKING STABILIZING PIN

J-PIN

(Order Separately)

1. LOOSEN SPARE TIRE AND REPOSITION IF NECESSARY. TIGHTEN AFTER HITCH INSTALLATION.
2. POSITION HITCH ON VEHICLE AS SHOWN, ALIGNING HOLES IN HITCH WITH EXISTING WELDNUTS IN VEHICLE FRAME (PASSENGER'S SIDE) AND SLOTS IN TOW-HOOK MOUNTING PAD (DRIVER'S SIDE). LOOSELY INSTALL HEX BOLTS AS SHOWN.

NOTE: FOR ISUZU RODEO AND HONDA PASSPORT

3. FISHWIRE CARRIAGE BOLT AND BLOCK (5121) THROUGH END OF FRAME ON PASSENGER'S SIDE AND INSTALL AS SHOWN.

NOTE: FOR ISUZU AXIOM ONLY

4. USING 1" DIA. HOLE SAW ENLARGE EXISTING HOLE ON PASSENGER'S SIDE OF FRAME AS SHOWN IN FIG. 1.
5. FISHWIRE CARRIAGE BOLT AND BLOCK (5121) THROUGH THE ENLARGED HOLE AND INSTALL AS SHOWN.

TIGHTEN ALL M12 CL8.8 FASTENERS TO 68 LB.-FT.

TIGHTEN ALL 1/2 GR5 FASTENERS TO 75 LB.-FT.

TIGHTEN ALL 5/8 GR5 FASTENERS TO 150 LB.-FT.

THIS PRODUCT COMPLIES WITH SAFETY SPECIFICATIONS AND REQUIREMENTS FOR CONNECTING DEVICES AND TOWING SYSTEMS OF THE STATE OF NEW YORK AND V.E.S.C. REGULATION V-5.

APPROX WEIGHT (LB.)
30.3

FASTENER KIT
F75093

NOTE: Check hitch frequently, making sure all fasteners and ball are properly tightened. If hitch is removed, plug all holes in trunk pan or other body panels to prevent entry of water and exhaust fumes. A hitch or ball which has been damaged should be removed and replaced. Observe safety precautions when working beneath a vehicle and wear eye protection. Follow car maker's specs for maximum trailer weight and tongue weight. Do not cut access or attachment holes with a torch.



CEQUENT®
TOWING PRODUCTS

PRINTED IN MEXICO