

AirCELL

by AIR LIFT®

Kit 52203

GM 1500
Rear application



INSTALLATION GUIDE

For maximum effectiveness and safety, please read these instructions completely before proceeding with installation.

Failure to read these instructions can result in an incorrect installation.

Installation Diagrams

(a) 1999-2007 4WD GMT800

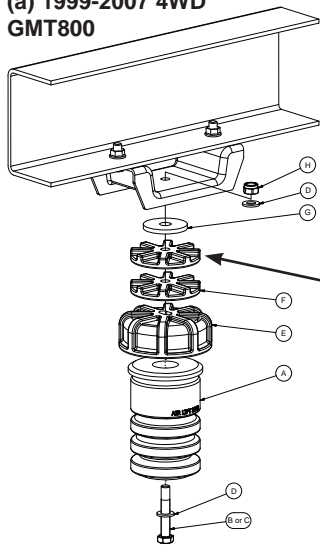

(b) 2007-2008 GMT900

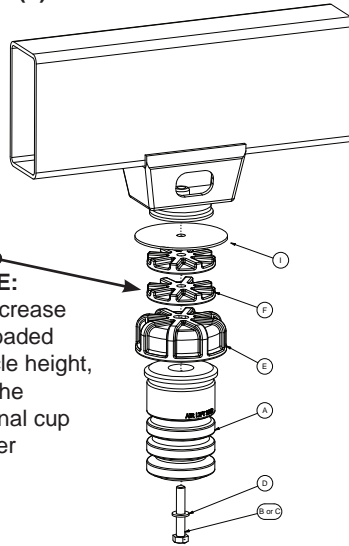

NOTE:
To increase the loaded vehicle height, add the optional cup spacer

(c) 1999-2007 2WD GMT800

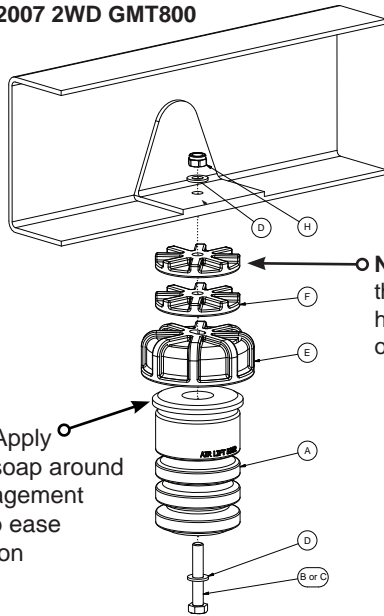

NOTE: To increase the loaded vehicle height, add the optional cup spacer

NOTE: Apply grease/soap around the engagement flange to ease installation

fig. 1 (a, b, c)

HARDWARE LIST

Item	Part #	Description.....Qty
A	52022	Spring.....2
B	17416	M10x1.5x60 Bolt.....2
C	17330	M10x1.5x30 Bolt.....2
D	18494	M10 Flat Washer.....4
E	10911	Spring Cup.....2
F	13244	Cup Spacer.....4
G	18207	Flat Washer (Large).....2
H	18495	M10 Nyloc Nut.....2
I	13241	Steel Spacer.....2

Important Safety Notice

The installation of this kit does not alter the Gross Vehicle Weight Rating (GVWR) or payload of the vehicle. Check your vehicle's owner's manual and do not exceed the maximum load listed for your vehicle.

Gross Vehicle Weight Rating: The maximum allowable weight of the fully loaded vehicle (including passengers and cargo). This number — along with other weight limits, as well as tire, rim size and inflation pressure data — is shown on the vehicle's Safety Compliance Certification Label.

Payload: The combined, maximum allowable weight of cargo and passengers that the truck is designed to carry. Payload is GVWR minus the Base Curb Weight.

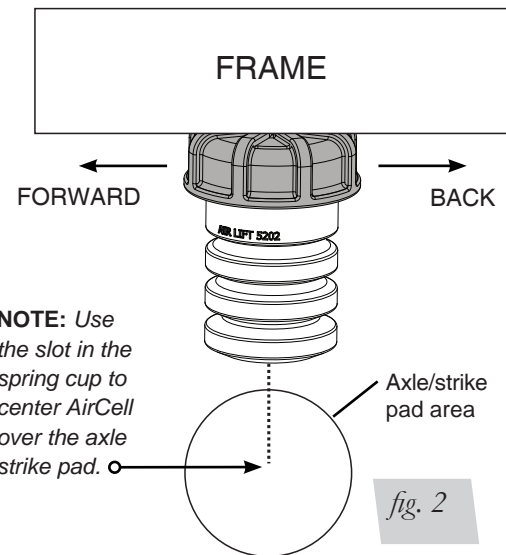

NOTE: Use the slot in the spring cup to center AirCell over the axle strike pad.

fig. 2

OPTIONAL: To increase the loaded vehicle height, add optional 1/2" spacer

TOOLS LIST

Description.....Qty
Hoist or floor jacks..... 1
Safety stands..... 2
Metric sockets..... 1
Metric wrenches..... 1
Ratchet..... 1



Missing or damaged parts? Call Air Lift customer service at (800) 248-0892 for a replacement part.

Installing the AirCell System

ASSEMBLING AND ATTACHING THE SYSTEM

1. Jack up the rear of the vehicle or raise on a hoist. Support the frame with safety stands. Lower the axle of the vehicle until the suspension is fully extended.
2. Remove the existing jounce bumper assembly on both sides.
3. For 2WD GMT800 and all GMT900 Models, using the existing frame hole that the stock jounce bumper was removed from, attach the spring cup and the bracket to the frame using the supplied M10 bolt, flat washers (use lock nut for the GMT800 only) (and the large steel spacer for the GMT900) (fig 1b & c). Torque the mounting hardware to 37ft/lbs.
4. For the 4WD GMT800 attach the spring cup to the existing jounce bumper bracket using an M10 bolt, flat washer through the spring cup, spring cup spacer, large flat washer, through the stock bracket and capped with a flat washer and nyloc nut (fig 1a). Torque the mounting hardware to 37ft/lbs.
5. Insert the spring into the cup. A twisting while pushing the spring into the cup will make the installation quicker. Make sure the spring snaps into position into the cup.

NOTE

Applying grease or soap around the engagement flange of the spring (A) will help in aiding the spring (A) to “snap” into the spring cup (E).

6. Do a quick check of the alignment. If needed, remove the spring and re-position the cup by using the slot for adjustment (fig 2). Once positioned correctly, re-torque the hardware and repeat spring installation if previously removed.

OPTIONAL

You can adjust the loaded height of the vehicle by adding the optional cup spacer between the cup and the bracket. It will be necessary to use the longer hardware provided to install the cup spacer (see fig 1 note).

Warranty and Returns Policy

Air Lift Company warrants its products, for the time periods listed below, to the original retail purchaser against manufacturing defects when used on catalog-listed applications on cars, vans, light trucks and motorhomes under normal operating conditions for as long as Air Lift manufactures the product. The warranty does not apply to products that have been improperly applied, improperly installed, used in racing or off-road applications, used for commercial purposes, or which have not been maintained in accordance with installation instructions furnished with all products. The consumer will be responsible for removing (labor charges) the defective product from the vehicle and returning it, transportation costs prepaid, to the dealer from which it was purchased or to Air Lift Company for verification.

Air Lift will repair or replace, at its option, defective products or components. A minimum \$10.00 shipping and handling charge will apply to all warranty claims. Before returning any defective product, you must call Air Lift at (800) 248-0892 in the U.S. and Canada (elsewhere, (517) 322-2144) for a Returned Materials Authorization (RMA) number. Returns to Air Lift can be sent to: Air Lift Company • 2727 Snow Road • Lansing, MI • 48917.

Product failures resulting from abnormal use or misuse are excluded from this warranty. The loss of use of the product, loss of time, inconvenience, commercial loss or consequential damages is not covered. The consumer is responsible for installation/reinstallation (labor charges) of the product. Air Lift Company reserves the right to change the design of any product without assuming any obligation to modify any product previously manufactured.

This warranty gives you specific legal rights and you may also have other rights that vary from state-to-state. Some states do not allow limitations on how long an implied warranty lasts or allow the exclusion or limitation of incidental or consequential damages. The above limitation or exclusion may not apply to you. There are no warranties, expressed or implied including any implied warranties of merchantability and fitness, which extend beyond this warranty period. There are no warranties that extend beyond the description on the face hereof. Seller disclaims the implied warranty of merchantability. (Dated proof of purchase required.)

AirCell	Lifetime Limited	Load Controller (I)	2 Year Limited
Air Lift 1000	Lifetime Limited	Load Controller (II)	2 Year Limited
RideControl	Lifetime Limited	SmartAir	2 Year Limited
SlamAir	Lifetime Limited	Wireless AIR	2 Year Limited
LoadLifter 5000*	Lifetime Limited	Other Accessories	2 Year Limited
EasyStreet Systems	1 Year Limited		<i>*formerly SuperDuty</i>

Replacement Information

If you need replacement parts, contact the local dealer or call Air Lift customer service at (800) 248-0892. Most parts are immediately available and can be shipped the same day.

Contact Air Lift Company customer service at (800) 248-0892, first if:

- Parts are missing from the kit.
- Need technical assistance on installation or operation.
- Broken or defective parts in the kit.
- Wrong parts in the kit.
- Have a warranty claim or question.

Contact the retailer where the kit was purchased:

- If it is necessary to return or exchange the kit for any reason.
- If there is a problem with shipping if shipped from the retailer.
- If there is a problem with the price.

Need Help?

Contact our customer service department by calling (800) 248-0892, Monday through Friday, 8 a.m. to 5 p.m. Eastern Time. For calls from outside the USA or Canada, our local number is (517) 322-2144.

**Register your warranty online at
www.airliftcompany.com/warranty**



Thank you for purchasing Air Lift products — the professional installer's choice!

Air Lift Company • 2727 Snow Road • Lansing, MI 48917 or PO Box 80167 • Lansing, MI 48908-0167
Toll Free (800) 248-0892 • Local (517) 322-2144 • Fax (517) 322-0240 • www.airliftcompany.com

Printed in
the USA