



CURTTM

The **FIRST** Name
in Towing ProductsTM

SPYDER GOOSENECK

INSTRUCTION MANUAL



Installer: Read and understand this manual. Fully instruct and demonstrate the operation of this gooseneck hitch to the end user. Include the importance of observing all warnings. Provide this manual in its entirety to the end-user.

16085

SPYDER GOOSENECK

2/23/2011

GROSS LOAD CAPACITY WHEN USED AS A WEIGHT CARRYING HITCH: 25,000 LBS. TRAILER WEIGHT & 6,250 LBS. TONGUE WEIGHT.
*****DO NOT EXCEED VEHICLE MANUFACTURER'S RECOMMENDED TOWING CAPACITY.*****

Parts List			
ITEM	QTY	PART NUMBER	DESCRIPTION
1	1	C-113	SAFETY CHAIN U-BOLT KIT
2	4	CM-16115-RHP	RAIL HAIRPIN
3	4	CM-16115-RMP 1/2" DIA	RAIL MOUNTING PIN

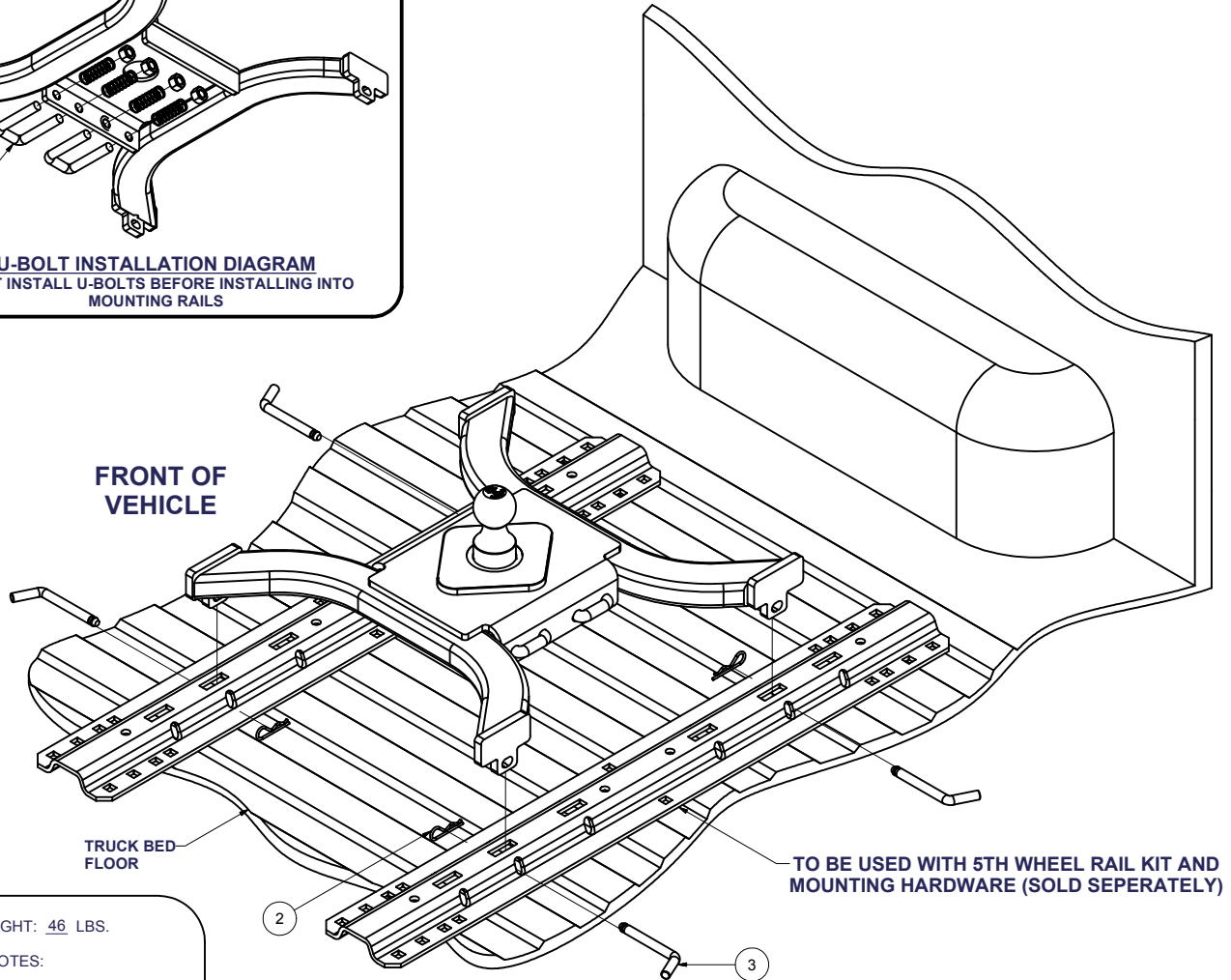
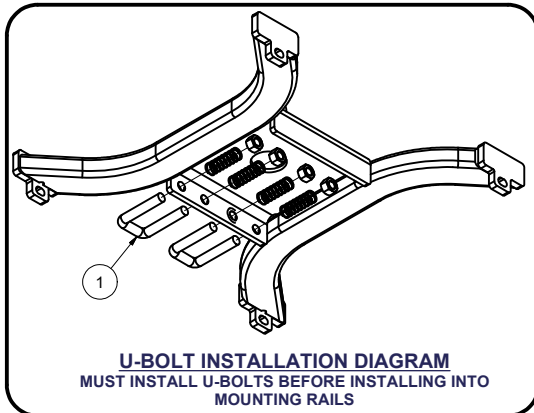

HITCH WEIGHT: 46 LBS.

INSTALL NOTES:

NO DRILLING REQUIRED

INSTALLATION STEPS

- 1) Before installing hitch, assemble U-bolts into gooseneck hitch as shown.
(Note: Install nut onto U-bolts just so the first threads start to protrude from the other side of the nut.)
- 2) Place hitch into mounting rails and insert pins. Secure pins by installing rail hairpins as shown.

PERIODICALLY CHECK THIS RECEIVER HITCH TO INSURE THAT ALL FASTENERS ARE TIGHT AND THAT ALL STRUCTURAL COMPONENTS ARE SOUND.

Curt Manufacturing LLC., warrants this product to be free of defects in material and/or workmanship at the time of retail purchase by the original purchaser. If the product is found to be defective, Curt Manufacturing LLC., may repair or replace the product, at their option, when the product is returned, prepaid, with proof of purchase. Alteration to, misuse of, or improper installation of this product voids the warranty. Curt Manufacturing LLC.'s liability is limited to repair or replacement of products found to be defective, and specifically excludes liability for incidental or consequential loss or damage.