

⚠ WARNING: Under no circumstances should the towing vehicle manufacturer’s recommended vehicle towing capacity be exceeded. Failure to follow instructions for installation and use may cause property damage, injury or death.

READ ALL INSTRUCTIONS BEFORE STARTING THE INSTALLATION OR USE

94920 – 20K Goosebox

20,000 lbs Rating
4,000 lbs. Max Pin Weight

Tools and Equipment Required to Install:

- Fastener kit 94621F (Included)
- 15/16” socket
- 15/16” wrench
- Torque wrench capable of going to 250 ft-lbs
- Lithium grease

**SAFETY
INSTRUCTIONS**

- Equipment for lifting approximately 250 lbs

What’s Included:

- 20K Goosebox
- Fastener Kit (94621F):
 - Hex Bolt – GR8 - 5/8”-11x2.00” – QTY 8
 - Conical Washer – 5/8” – QTY 8
 - Flat Washer – 5/8” – QTY 8
 - Hex Nut – GR8 - 5/8”-11 – QTY 8

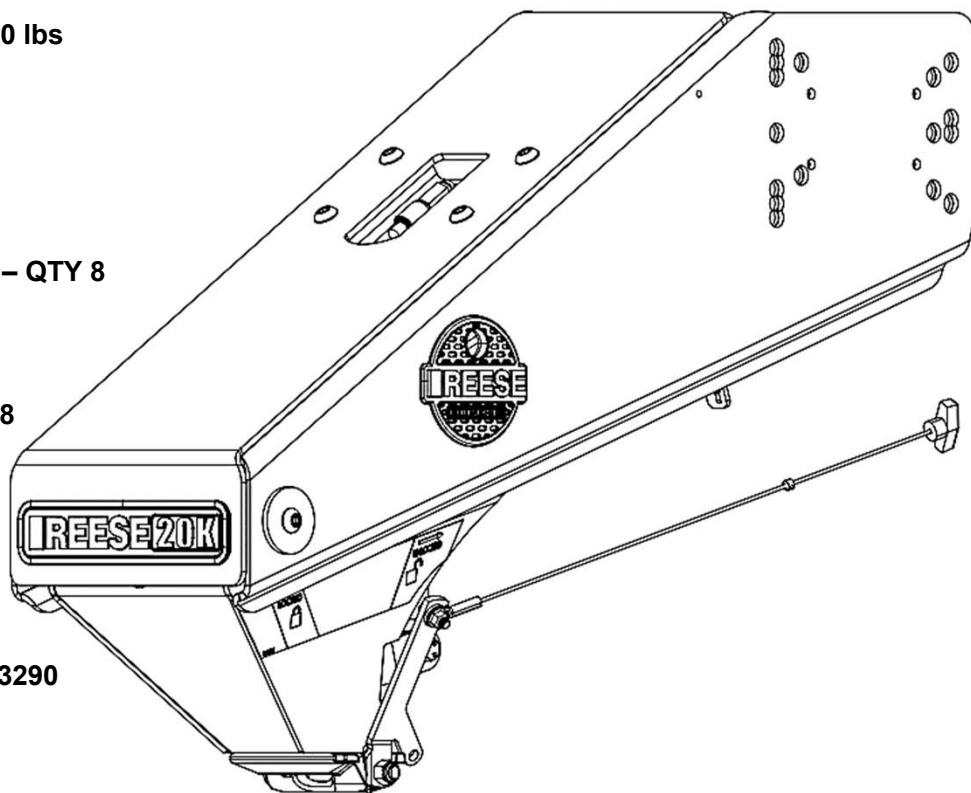

NOTE: For any questions, please

- Scan QR code
- Visit <https://qr.towingproducts.net>
- Or call Technical Service at: 1-800-632-3290



Table of Contents

Safe Towing.....p 2	Typical Bolting.....p 12
Trailer Guidelines.....p 3	Air Fill/Adjustment.....p 13
Product Warnings.....p 4	Maintenance.....p 15
Hitching/Unhitching.....p 7	Locking Instructions.....p 16
Matching Wing Setsp 9	Warranty.....p 17

Guidelines for Matching Tow Vehicle and Trailer

Failure to check and follow tow ratings could result in tow vehicle damage or truck and trailer separation while towing.

- Trailer and its contents together must not exceed truck, hitch and/or trailer tow ratings.
- Towing vehicle must have a manufacturer's rated towing capacity equal to or greater than the gross trailer weight (dry weight of the trailer plus payload of the trailer) (Figure 1).
- Gross weight of trailer must not exceed 20,000 pounds for part number 94920.
- Gooseneck ball vertical weight (Pin Weight) must not exceed 4,000 pounds for part number 94920 (Figure 2).

Figure 1

FACTORY TRAILER + FULL WATER TANKS
+ CARGO, ETC. = GROSS TRAILER WEIGHT



1. Check Tow Ratings:

Vehicle Tow Rating: _____.

Goosebox Rating: 20,000 lbs.

*Gross Trailer Weight (Figure 1): _____.

***Gross trailer weight should be the lowest of these recorded ratings for safe towing conditions.**

Figure 2

20% MAX. GROSS
TRAILER WEIGHT
(PIN WEIGHT)

80% GROSS
TRAILER WEIGHT

2. The Goosebox is designed for a maximum of 20% Gross Trailer Weight on the gooseneck ball (Vertical Pin Weight) (Figure 2).

Guidelines for Matching Tow Vehicle and Trailer**CAUTION**

Due to Vehicle and RV Trailer variations, it is necessary to check the rear bumper to trailer clearance. If the clearance is less than 2 feet, this check can be done after installation by making a slow turn, in a controlled driving environment (i.e. closed parking lot, grass field, etc.) with the aid of an observer to watch for interference.

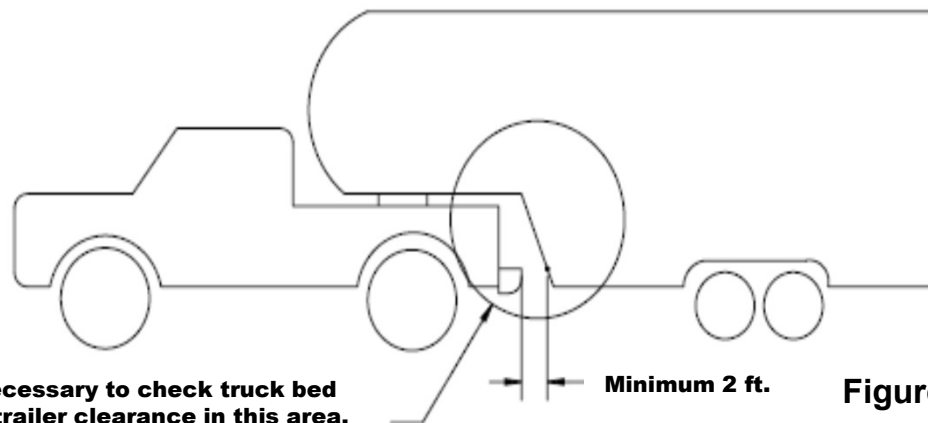
**Figure 3**

1. A minimum clearance between the bumper and trailer (Measured at the same height) of 2 feet is recommended (Figure 3).

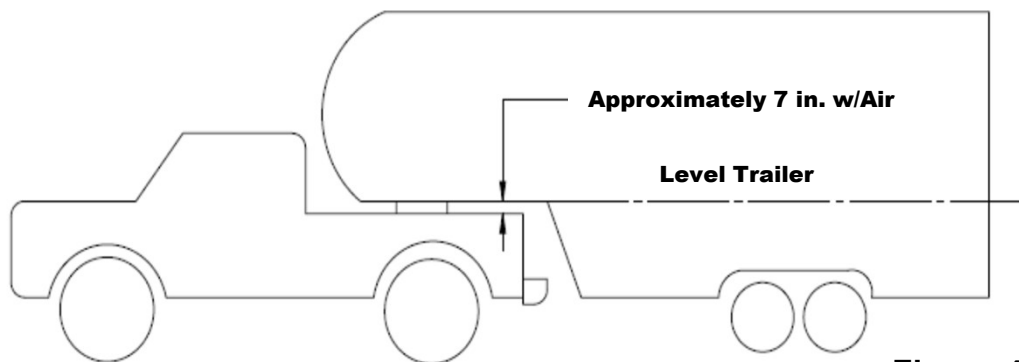
**Figure 4**

2. The height of the Goosebox should be adjusted such that the trailer is approximately level as it is towed. Allow approximately 7 inches clearance between the top of the bedside and the underside of the front of the trailer for pitch and yaw of the trailer (Figure 4).

CAUTION For off-road use, monitor closely and allow more clearance between pickup bedsides and trailer.

CAUTION

The Measurements in Figures 3 & 4 are guidelines; if the taken measurements are close to these numbers, re-check clearances. If vehicle and/or trailer has any added vanity accessories (i.e. fairings, air dams, ground effects, bed rails, etc.) additional dimensioning and clearance checks must be made. Horizon Global is not responsible for damage incurred due to disregarding these clearance checks.

Product Pinch Points



Goosebox has multiple pinch points that can cause serious injury. Keep fingers and all other body parts away from any of the listed pinch points. Placing a body part or object anywhere else, except the air inflation valve could cause damage or serious injury

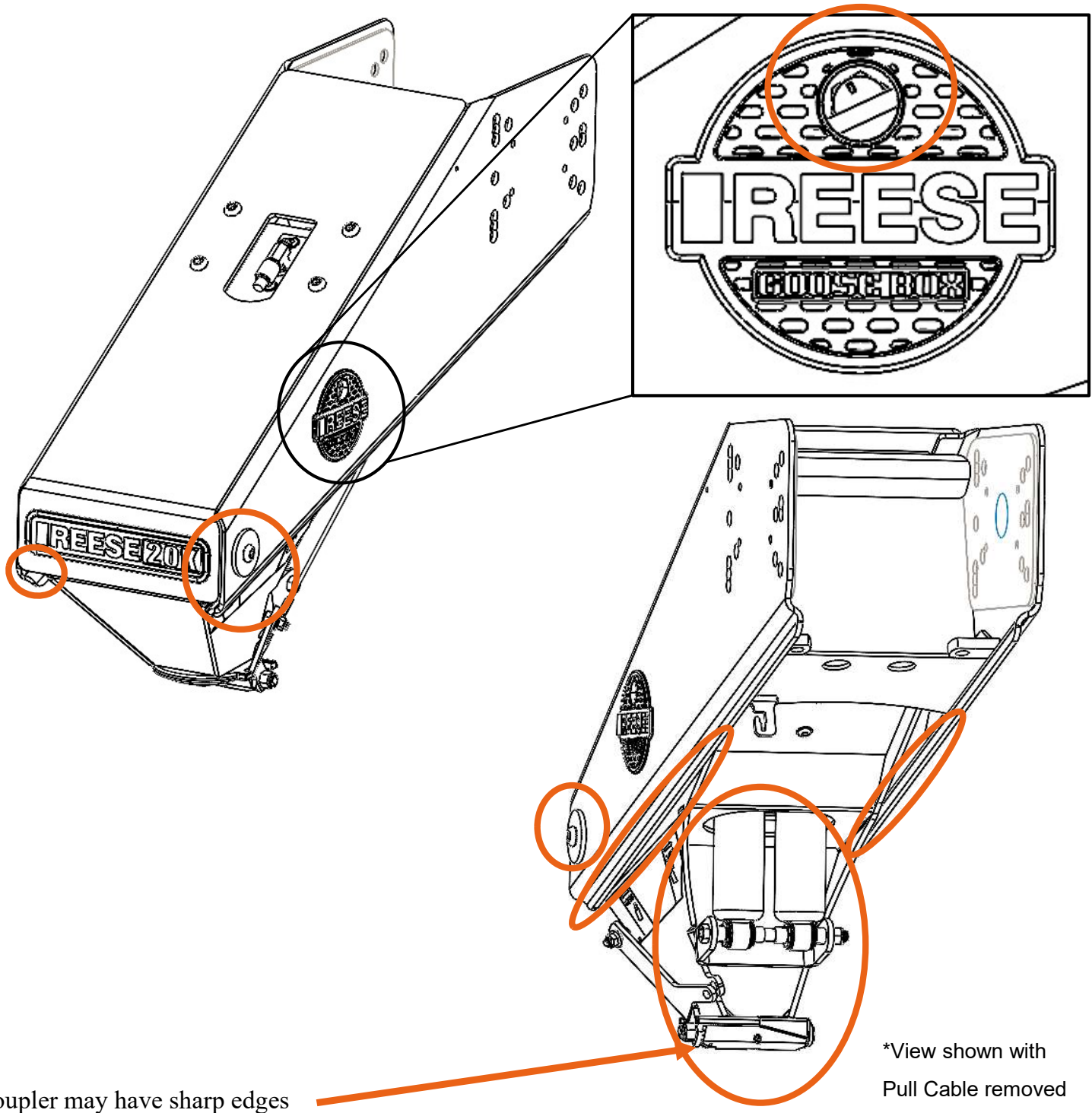

Coupler may have sharp edges

*View shown with
Pull Cable removed

Figure 5

Recommendations for Safe Towing**SAFETY
INSTRUCTIONS**

- Fully understand the manufacture's tow ratings of the truck being used.
 - Do not exceed these ratings.
- Ensure rearview mirrors are properly adjusted.
- Ensure brake controller is properly adjusted and operating correctly.
- Take wide turns to ensure proper clearance between trailer and obstacles.
- Ensure breakaway switch is securely mounted and free from obstructions.
 - Cable should be free of snags through full turning radius.
- Ensure safety chains (if equipped) are securely mounted and free from obstructions.
 - Chains should be free of snags through full turning radius.
- All coupling surfaces should be clean of dirt and debris, and lightly greased.
- Use E-rated tires.
 - Ensure tires are properly inflated.
- Airbags (if equipped) should be inflated to the proper pressure.
 - Truck should be level when trailer is attached and loaded.
- Clearance between top of bed sides and underside of trailer nose should be approximately 7 inches.
 - Allow more clearance if using in off-road applications.
- Truck and trailer should be loaded evenly and to not exceed manufacturer's rating.
 - Do not load trailer heavier behind axle(s).
 - Overloading may result in serious personal injury or death, vehicle crash, and/or property damage.

REESE Goosebox

IMPORTANT INFORMATION ON TOWING



Failure to heed warnings and follow instructions may result in serious personal injury or death, vehicle crash, and/or property damage.

- **Do not modify.**
- **Do not tow one trailer behind another (Tandem Towing), this may cause loss of control.**

TOWING EQUIPMENT OWNERS

Make sure all operators of equipment read and understand this information before towing. Save for reference. This will help ensure proper use and maintenance of towing equipment. Refer to owner's manuals for tow vehicle, trailer and other parts of the towing system. Learn the capabilities and limitations of each part. GROSS TRAILER WEIGHT and PIN WEIGHT are the two most important items to consider.

THESE WEIGHTS MUST NEVER EXCEED THE LOWEST RATING OF ANY PART OF THE TOWING SYSTEM.

GROSS TRAILER WEIGHT is the weight of the trailer plus cargo. Measure GROSS TRAILER WEIGHT by putting the fully loaded trailer on a vehicle scale. PIN WEIGHT is the downward force exerted on the gooseneck ball by the Goosebox. Use a vehicle scale to measure PIN WEIGHT with the fully loaded trailer on a level surface and the Goosebox at normal towing height.

TRAILER COUPLING

The gooseneck ball and coupler should be smooth, clean and lightly lubricated. Adjust per manufacturer's instructions.

SAFETY CHAINS

Connect safety chains properly EVERY TIME YOU TOW. Leave only enough slack to permit full turning. Too much slack may prevent chains from maintaining control if other connections separate.

TRAILER LIGHTS, TURN SIGNALS, ELECTRIC AND BREAKAWAY SWITCH CONNECTIONS

Make these safety-critical connections EVERY TIME YOU TOW, no matter how short the trip. Check operation, including electric brake manual control, before getting on the road.

TIRE INFLATION

Check often. Follow tow vehicle and trailer manufacturer's recommendations.

CHECK YOUR EQUIPMENT/REPLACE WORN PARTS

Check gooseneck ball, coupler, chains, and all other connections EVERY TIME YOU TOW. Re-check at fuel and rest stops.

NO PASSENGERS IN TRAILER!

NEVER allow people in the trailer while towing, under any circumstances.

TRAILER LOADING

Place heavy objects on the floor ahead of the axle. Balance the load side-to-side. Secure it to prevent shifting. NEVER load the trailer rear heavy. **LOAD THE TRAILER HEAVIER IN THE FRONT, BUT NOT GREATER THAN PIN WEIGHT RATING.**

DRIVING

The additional weight of a trailer affects acceleration, braking and handling. Allow extra time for passing, stopping, and changing lanes. A gooseneck trailer requires a large turning radius as the trailer tracks to the inside of turns. Severe bumps can damage towing vehicle, hitch and trailer. Drive slowly on rough roads. **STOP AND MAKE A THOROUGH INSPECTION IF ANY PART OF THE TOWING SYSTEM STRIKES THE ROAD. CORRECT ANY PROBLEMS BEFORE RESUMING TRAVEL.**



Failure to follow this instruction may result in the coupler being too high and coming to rest on top of the gooseball. This could result in trailer separating from the truck. Trailer separation may result in death or serious injury if anyone is under the trailer or between truck and trailer when separation occurs.

HITCHING:

1. Place blocks (sometimes called “chocks”) firmly against front and rear of each trailer tire to prevent any possible forward or rearward motion. **DO NOT REMOVE BLOCKS UNTIL EACH OF THE FOLLOWING STEPS AND THE PULL TEST HAVE BEEN COMPLETED.** Lower tailgate if necessary. Clearance of the lowered tailgate to the trailer needs to be monitored during hookup as some manufacturer combinations of truck and trailer have little or no clearance.

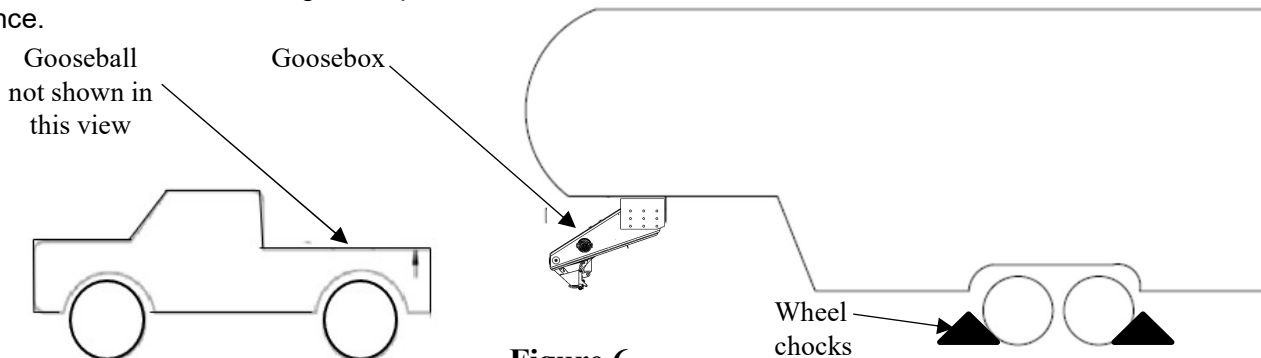

Figure 6

IMPORTANT: YOU ARE RESPONSIBLE FOR SAFE HITCHING AND UNHITCHING OPERATIONS. DO NOT RELY ON OTHERS TO PERFORM THESE DUTIES. YOU MUST PERSONALLY MAKE SURE THE FOLLOWING STEPS ARE PERFORMED IN THE FOLLOWING ORDER!

2. Ensure that the Gooseball is locked within the housing of the truck bed. Use only with 2 5/16” diameter gooseneck ball.
3. Ensure coupler handle is in the locked position and not limited by the pull cable or debris (Figure 7).
4. Back the truck into trailer slowly until the coupler of Goosebox is above the gooseball .
5. Lower coupler onto gooseneck ball. The Goosebox coupler handle will open, then snap shut.
6. Make certain handle has returned forward and is in the locked position before towing.

NOTE:

- 1) Visually inspect from the side of your vehicle that the gooseneck ball is completely recessed inside the Goosebox coupler.
- 2) After the handle is in the locked position, raise the trailer jacks to ensure the Goosebox is locked onto the gooseneck ball.

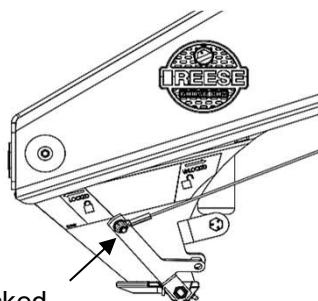

Handle In Locked Position

Figure 7

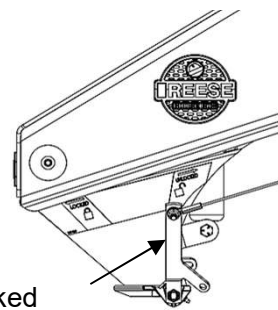

Handle In Unlocked Position

Figure 8

Goosebox**94920**

Unstable or improperly hitched trailers can fall or separate and cause serious injury or death:

- **Never** attempt to hitch trailer without first reading and following all instructions in the manual provided with this product. Do not use without reading and understanding the manual.
- **Never** tow a trailer that exceeds all rated capacities. Towing a trailer that exceeds all rated capacities can result in trailer separation, serious injury, or death. The combined weight of the trailer and its contents must not exceed the lowest truck, hitch, and trailer weight and tow rating
- **Never** allow any part of the body to be placed under the trailer or between the truck and trailer.
- **Keep hands clear** when operating coupler mechanism.

UNHITCHING:

1. Ensure truck is in park with emergency brake on.
2. Place blocks firmly against front and rear of each trailer tire to prevent any possible forward or rearward motion.
3. Lower trailer landing gear following the directions in the Trailer Manual until feet of landing gear are resting on firm ground.
4. Lower truck tailgate.
5. Disconnect power cable and breakaway switch cable between truck and trailer.
6. Using pull cable, pull handle back and hook cable stop onto the bracket. Handle should be in the Unlocked position (Figure 13).
NOTE: If necessary, adjust the cable stop by loosening the small set screw (Allen wrench size is 0.050"), moving the cable stop, and then retightening.
7. Raise trailer until bottom of coupler is approximately one inch above top of gooseneck ball, then release cable.
8. Ensure coupler latch returns to locked position.

Matching Wing Sets (Examples)

Lippert 1621 (2 mounting positions that provide 2 inches of adjustment)

Figure 9:

Lippert 1621 Standard Mounting Position

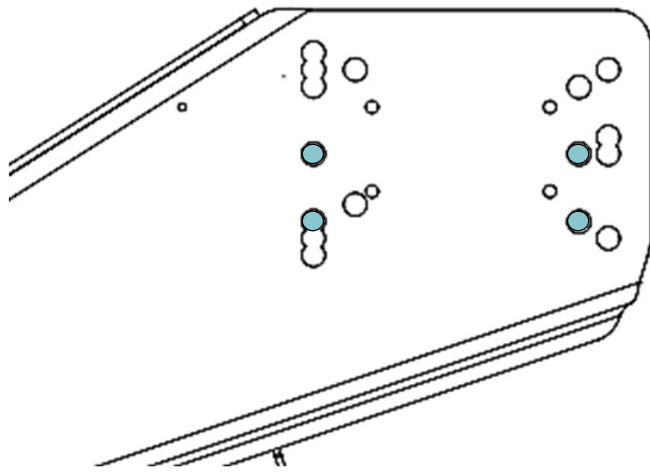

Bolt Locations

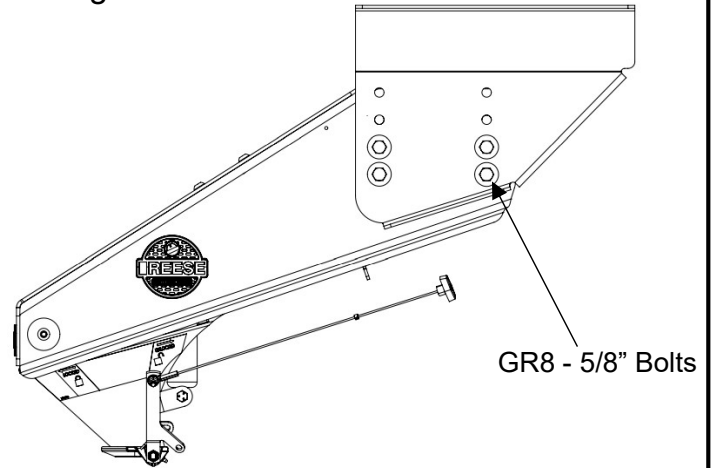

Trailer Forward

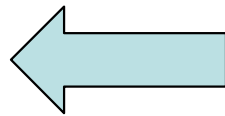
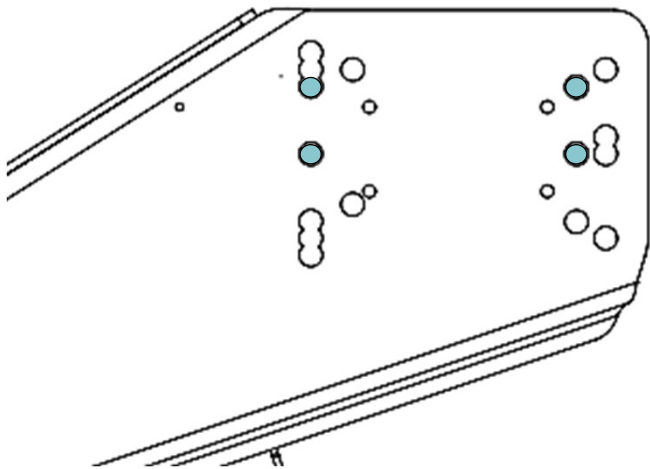
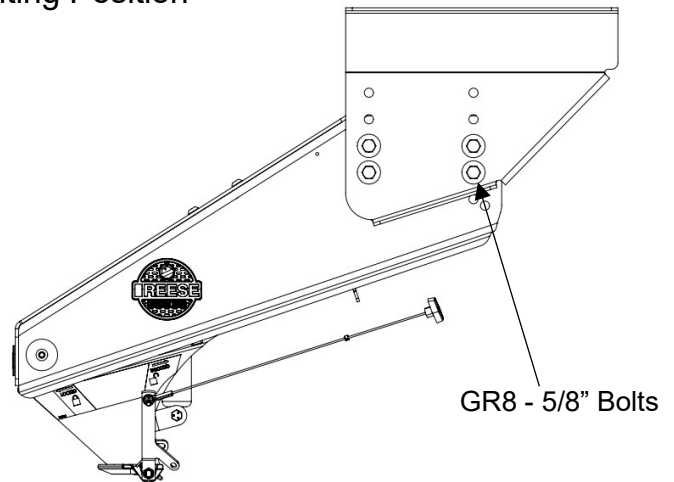

Figure 10:

Lippert 1621 Lowest Mounting Position



Bolt Locations



Trailer Forward

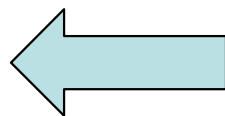

NOTE: For other wing sets, please

- Visit <https://qr.towingproducts.net>
- Or call Technical Service at: 1-800-632-3290

Matching Wing Sets (Examples)**Lippert 1716 (2 mounting positions that provide 2-1/2 inches of adjustment)****Figure 11:**

Lippert 1716 Standard Mounting Position

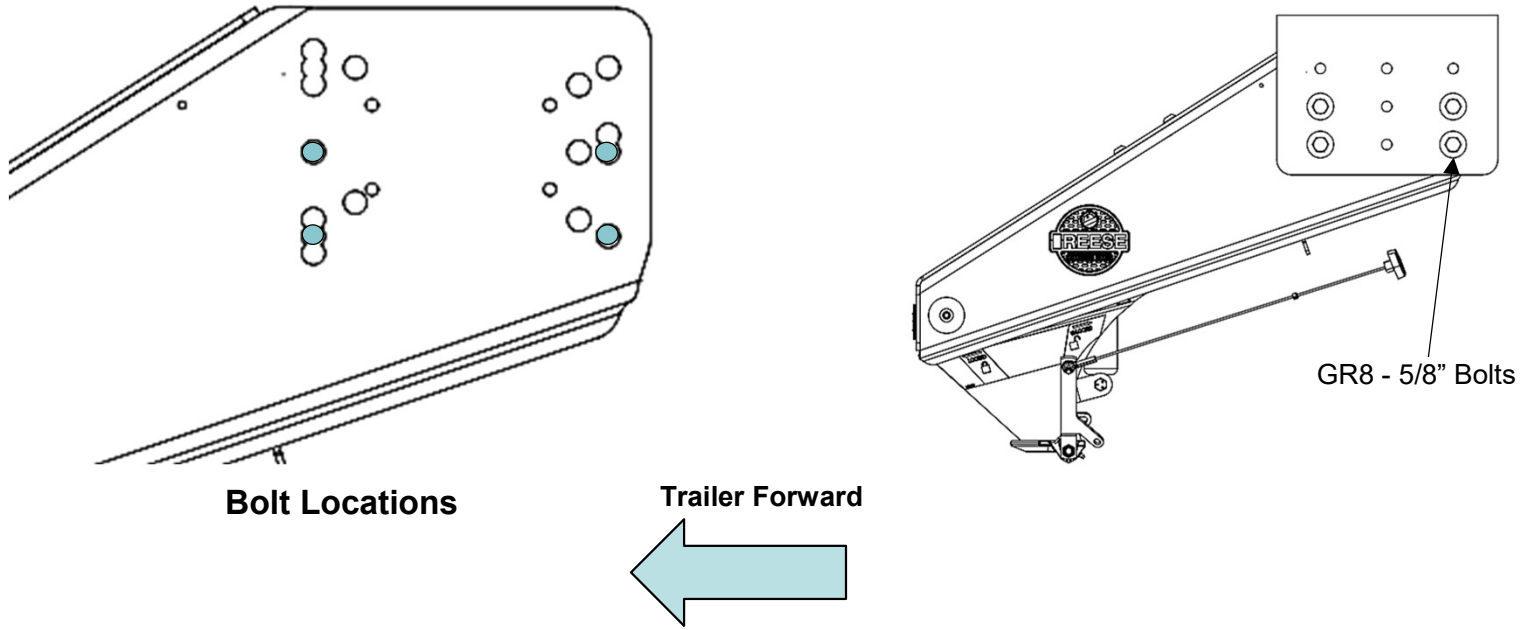
**Figure 12:**

Lippert 1716 Lowest Mounting Position

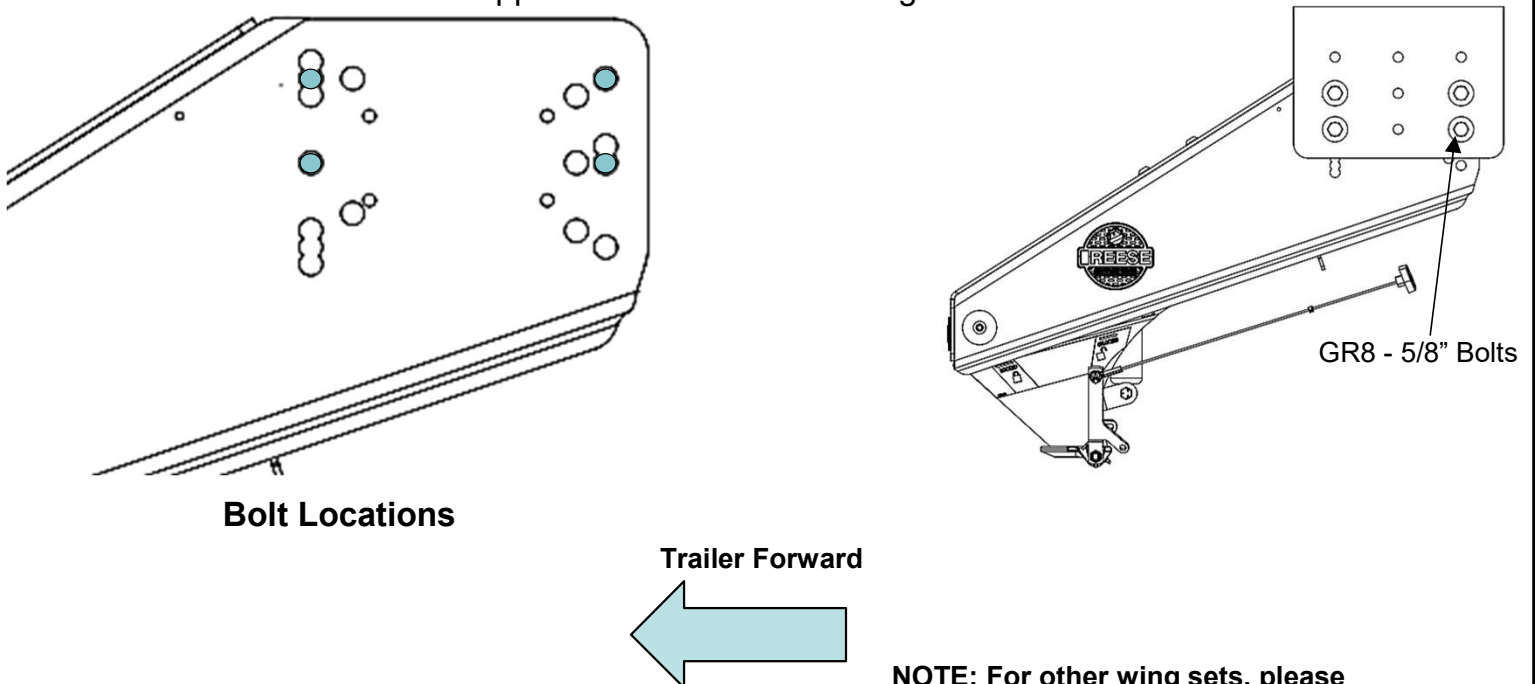
**NOTE:** For other wing sets, please

- Visit <https://qr.towingproducts.net>
- Or call Technical Service at: 1-800-632-3290

Matching Wing Sets (Examples)

Lippert Rhino (1 mounting position)



Rhino bolt hole application has a maximum load of 20,000 lbs

Figure 13:

Lippert Rhino Mounting Position

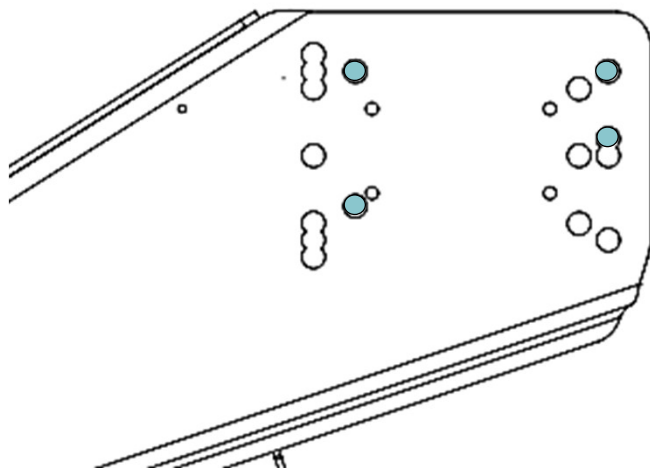

Bolt Locations

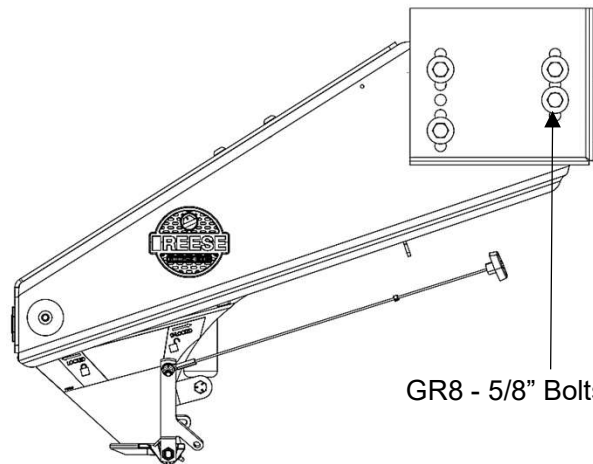

GR8 - 5/8" Bolts

Trailer Forward

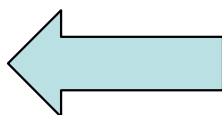

NOTE: For other wing sets, please

- Visit <https://qr.towingproducts.net>
- Or call Technical Service at: 1-800-632-3290

Typical Bolting

NOTE: The Figure Shows a Typical Installation.

The trailer wing is moved away to better show the hardware installation.

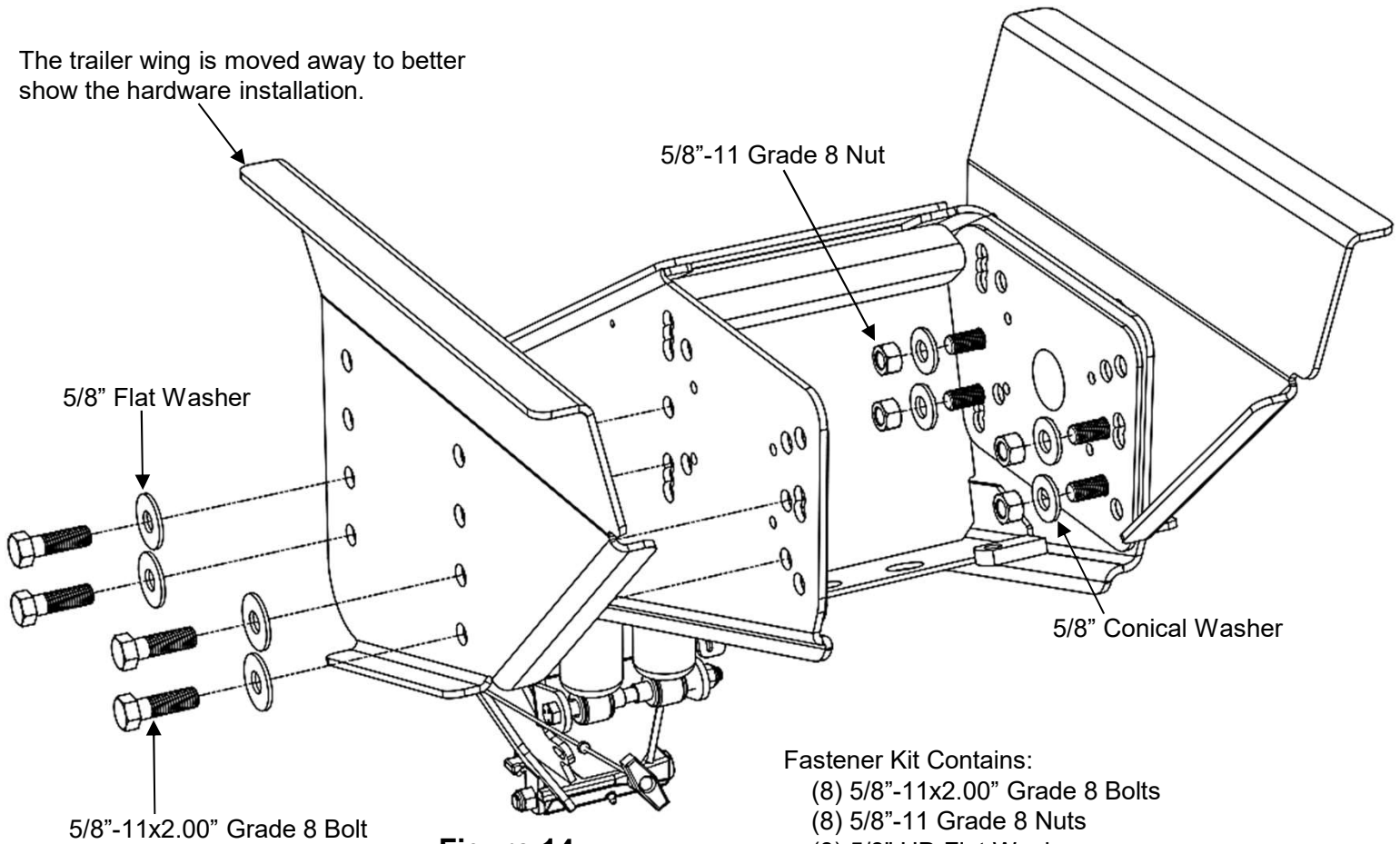

Figure 14

Fastener Kit Contains:

- (8) 5/8"-11x2.00" Grade 8 Bolts
- (8) 5/8"-11 Grade 8 Nuts
- (8) 5/8" HD Flat Washers
- (8) 5/8" Conical Lock Washers

Bolts & Flat Washers Are Installed From The Outside, Conical Lock Washers and Nuts On the Inside.



Torque Bolts To 210 ft-lbs.

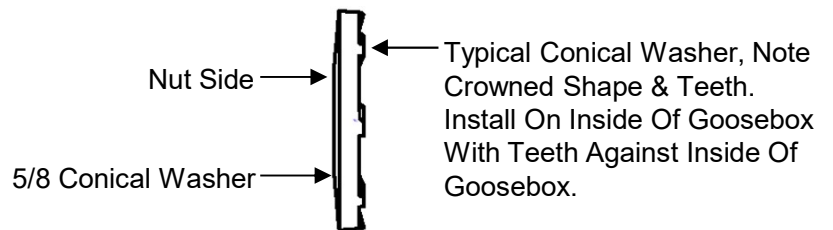
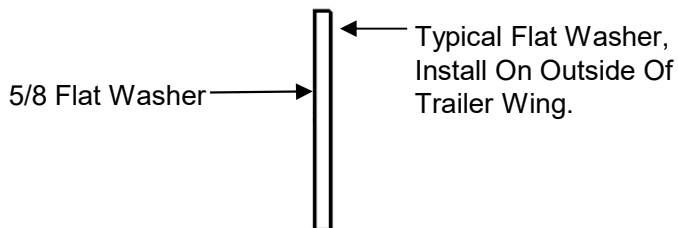

Air Fill / Adjustment

Filling the Goosebox air system may require 2 people. One person will need to fill the system while the other watches the Air Inflation Visual Indicator. Horizon Global advises against filling the air system with only one person.

Before filling the air system, perform these safety steps and ensure:

1. Ensure that you are 100% coupled, coupler latched and locked. Refer pages 7 and 8 for hitch and locking procedures.
2. Ensure that your trailer and tow vehicle are on level ground with your vehicle in park and the park brake applied.
3. Ensure that the tow vehicle and trailer are secured ie: have blocks (chucks) that are positioned firmly against front and rear of each towing vehicle and trailer tire to prevent any possible forward or rearward motion. **DO NOT REMOVE BLOCKS UNTIL EACH OF THE AIR FILL STEPS HAVE BEEN COMPLETED.**

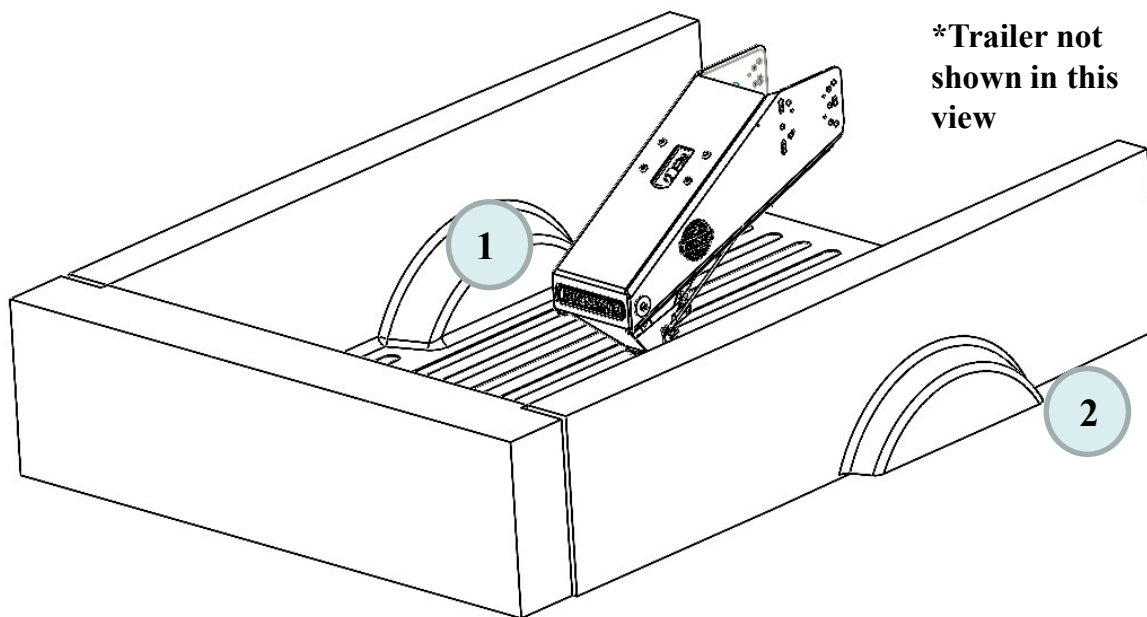

Figure 15

When filling the air system, 2 people may be required:

1. One person should be in the truck in order to fill the air valve (shown at position 1 of figure 15).
2. The second person should be standing outside of the truck watching the Air Inflation Visual Indicator. (Shown at Position 2 of figure 15).

Warning: DO NOT PUT ANYTHING IN THE INDICATOR.



Air Fill / Adjustment



*May rotate up to 7 degrees in either direction. Rotation does not affect functionality

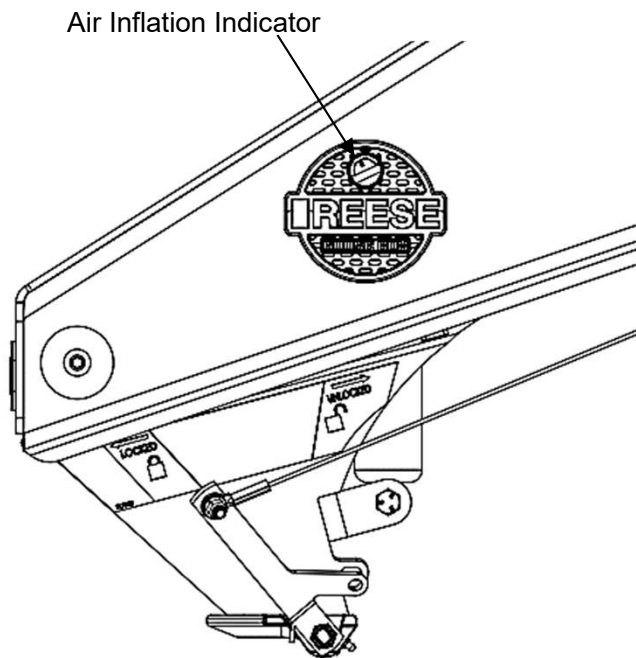

Figure 16

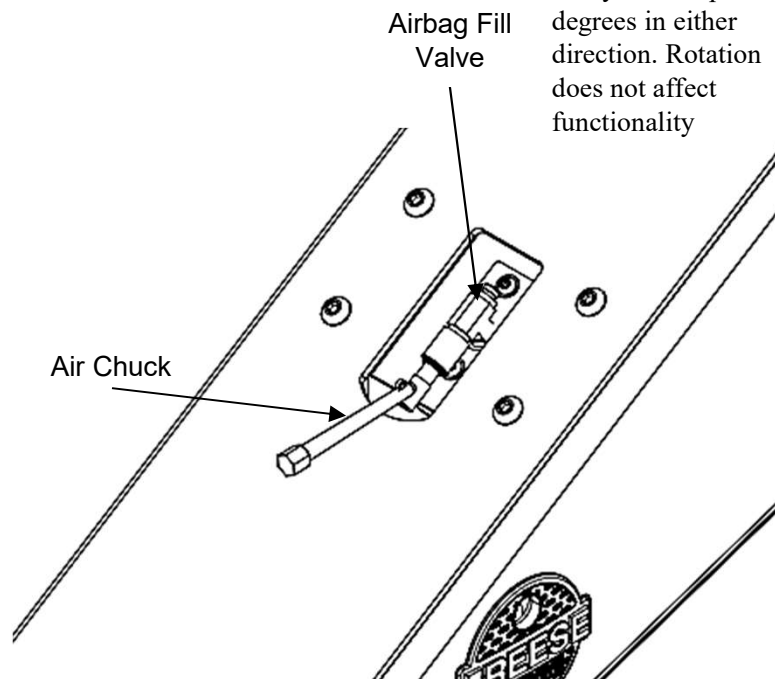

Figure 17

ADJUSTING THE AIR SPRING

1. Perform the safety steps on page 7 before adjusting suspension air pressure, with the trailer loaded.
 2. With trailer hitched to truck and landing gear/jacks retracted, add air to the airbag fill valve as shown in Figure 17.
- NOTE:** Air should **only** be added with air chuck in location shown in Figure 17.
3. One person will fill the Goosebox at the inlet. The second person will watch until it is at its nominal position (seen in the air inflation visual indicator) (Figure 18)
 4. Re-check Air Inflation Indicator and inflate to desired ride comfort position.

NOTE: The Goosebox airbag fill valve is equipped with an automatic air relief valve. If the airbag is over inflated, the relief valve will activate and release air to a safe level.



Do not insert fingers or any body parts into the air inflation indicator. Doing so may result in serious injury. It is unsafe to put anything into the visual indicator.

Figure 18:
Nominal Air
Position



Figure 19:
Maximum Air
Position



Figure 20:
Low Air
Position



Maintenance

To ensure long term performance, it is recommended to follow the following maintenance:

1. Grease coupler shaft from fitting on backside of coupler before each use (Figure 21).
 2. Clean and grease the gooseneck ball.
 3. Grease the main pivot shaft from fitting on inner bushing before each use (Figure 22).
- NOTE:** Deflating the airbag may make accessing grease fitting easier.
4. Inspect the Goosebox for any damage or excessive wear.
 5. Once per season, fully deflate the airbag and then refill.
 6. Perform normal maintenance when taking out of storage.

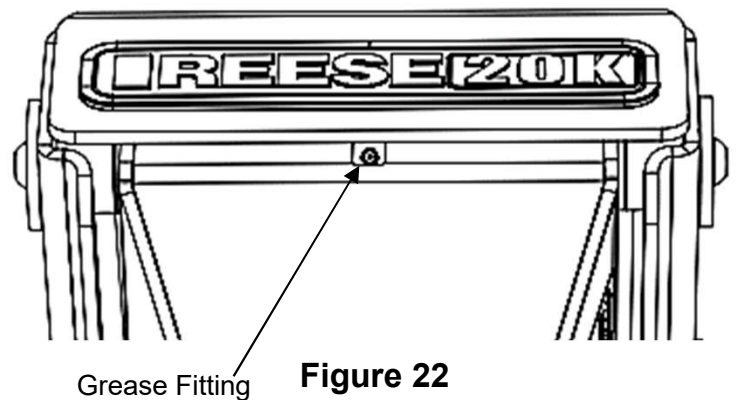
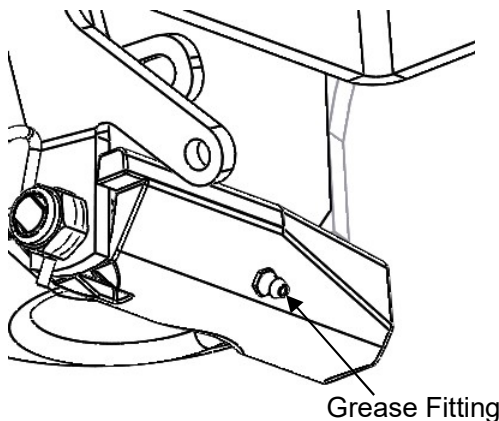
Figure 21

BEFORE EACH TRIP:

1. **CHECK YOUR EQUIPMENT:** Check the condition of all towing equipment and keep it in proper working condition.
2. Check to see that all bolts and nuts are properly tightened.
3. Check that the airbag pressure is set for your vehicle and loaded trailer.

NOTE: The airbag can lose pressure with temperature changes when not in use.

4. Check the functionality of the coupler pull handle to make sure it moves in both the locked and unlocked positions.

Safety Chain Hangers

For added safety, please use the Reese 20K Rated Safety Chain (part number 49151).

When not in use, put the safety chain hooks into the supplied safety chain holes for proper storage.

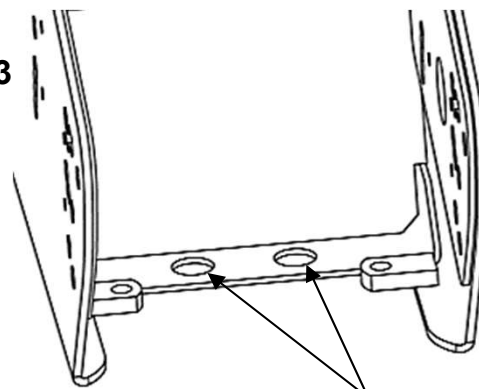
Figure 23**Safety Chain Hanger Location**

Optional Lock Location

When hitched up or when the trailer is in storage, a lock may be used for theft prevention in the lock location shown in Figure 24. A commonly available lock that meets the dimensions in Figure 25 may be used (example: Master Lock #5).

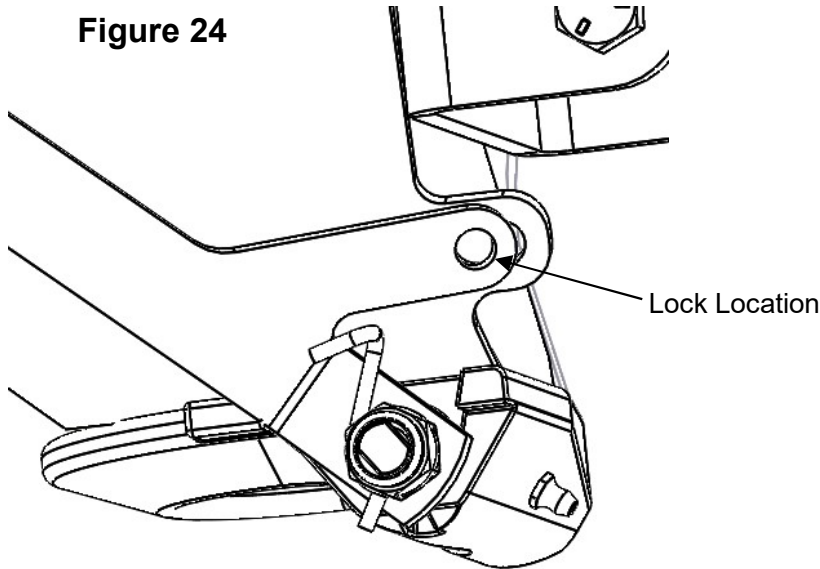
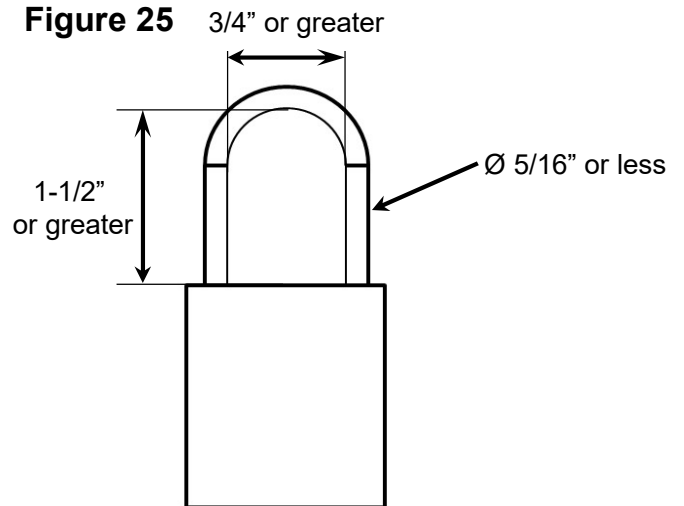
Figure 24**Figure 25**

Breakaway Switch Mounting Location

To help ensure a safe towing experience, a breakaway switch can be mounted in the location shown in Figure 26. The breakaway switch can be mounted on the left or right side of the Goosebox.

NOTE: The breakaway cable should be long enough to allow for full turning radius of the truck and trailer.

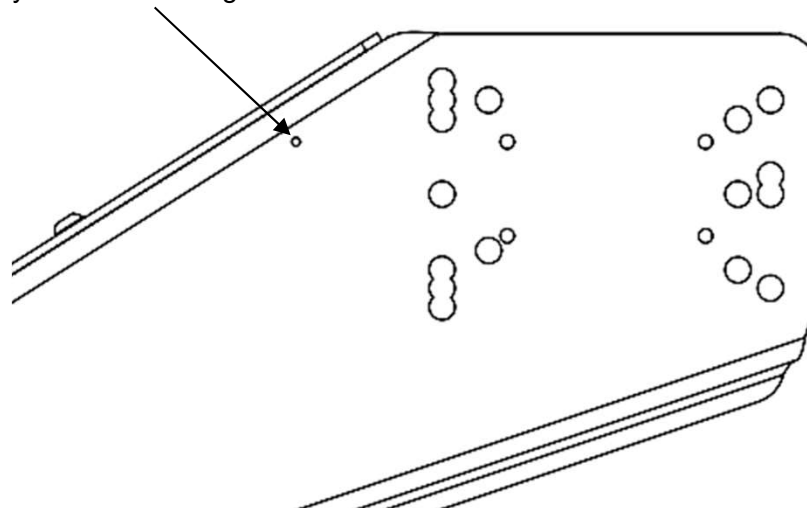
Breakaway Switch Mounting Location**Figure 26**



Product Instructions:

20K Goosebox

NOTES:

Part Number Purchased:
Place of Purchase:
Date of Purchase:
Part Manufactured Date (located on driver-side sticker):

LIMITED LIFETIME WARRANTY

- 1. **Limited Lifetime Warranty (“Warranty”).** Horizon Global (“We” or “Us”) warrants to the original consumer purchaser only (“You”) that the product will be free from material defects in both material and workmanship for a period of lifetime of ownership, ordinary wear and tear excepted; provided that installation and use of the product is in accordance with product instructions. There are no other warranties, express or implied, including the warranty of merchantability or fitness for a particular purpose. This warranty is not transferable.
- 2. **Limitations on the Warranty.** This Warranty does not cover: (a) normal wear and tear; (b) damage through abuse, neglect, misuse, or as a result of any accident or in any other manner; (c) damage from misapplication, overloading, or improper installation; (d) improper maintenance and repair; and (e) product alteration in any manner by anyone other than Us, with the sole exception of alterations made pursuant to product instructions and in a workmanlike manner.
- 3. **Obligations of Purchaser.** To make a Warranty claim, contact Us at 47912 Halyard Drive Suite 100, Plymouth, MI, 48170, 1-800-632-3290, identify the product by model number, and follow the claim instructions that will be provided. Any returned product that is replaced by Us becomes our property. You will be responsible for return shipping costs. Please retain your purchase receipt to verify date of purchase and that You are the original consumer purchaser. The product and the purchase receipt must be provided to Us in order to process Your warranty claim.
- 4. **Remedy Limits.** Product replacement is Your sole remedy under this Warranty. We shall not be liable for service or labor charges incurred in removing or replacing a product or any incidental or consequential damages of any kind.
- 5. **Assumption of Risk.** You acknowledge and agree that any use of the product for any purpose other than the specified use(s) stated in the product instructions is at Your own risk.
- 6. **Governing Law.** This Warranty gives You specific legal rights, and You also may have other rights which vary from state to state. This Warranty is governed by the laws of the State of Michigan, without regard to rules pertaining to conflicts of law. The state courts located in Oakland County, Michigan shall have exclusive jurisdiction for any disputes relating to this Warranty.

Horizon Global America, Inc
47912 Halyard Drive Suite 100
Plymouth, MI 48170

