

STAKE POCKET SPARE TIRE CARRIER

RHSC-30

TOOLS REQUIRED:

DRILLS: NONE

WRENCHES: RATCHET, TORQUE WRENCH,
9/16" SOCKET

THIS PRODUCT IS INTENDED FOR USE AS A SPARE TIRE CARRIER AND SHOULD NOT BE USED FOR ANY OTHER PURPOSE. MAKE SURE THE SPARE TIRE IS ATTACHED SECURELY TO THE CARRIER BEFORE DRIVING.

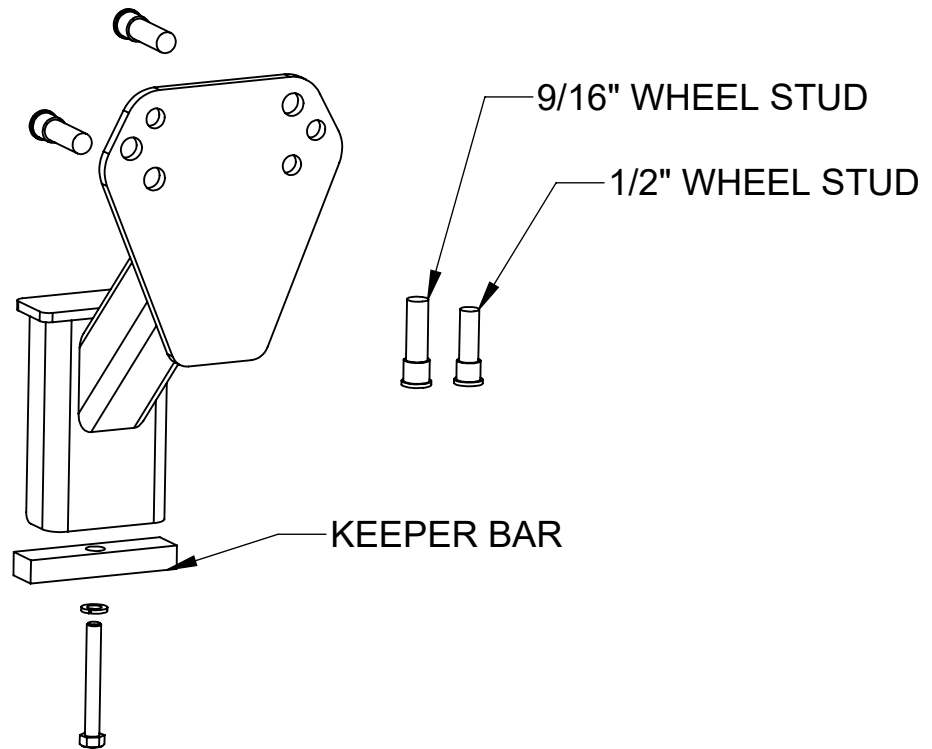

1. CHOOSE WHICH WHEEL STUDS BEST SUIT YOUR SPARE 9/16" OR 1/2".
2. USING YOUR SPARE AS A REFERENCE SELECT TWO MOUNTING HOLES THAT ALIGN WITH THE BOLT PATTERN ON YOUR SPARE AND INSERT THE WHEEL STUDS PROVIDED.
3. INSERT SPARE TIRE CARRIER INTO STAKE POCKET. SECURE WITH KEEPER BAR AND 3/8" HEX BOLT. TORQUE BOLT TO 23 FT-LB.
4. MOUNT SPARE TIRE ONTO WHEEL STUDS AND SECURE WITH LUG NUTS PROVIDED.

NOTE: THERE WILL BE UNUSED HARDWARE AFTER INSTALLATION

THANK YOU FOR PURCHASING A RIGID HITCH MADE PRODUCT

HARDWARE INCLUDED:

- (1) 3/8"-16 X 3" HEX BOLT
- (1) 3/8" LOCK WASHER
- (2) 9/16" WHEEL STUDS

- (2) 1/2" WHEEL STUDS
- (2) 9/16" LUG NUTS
- (2) 1/2" LUG NUTS

GIVE THIS INSTRUCTION SHEET TO VEHICLE OWNER

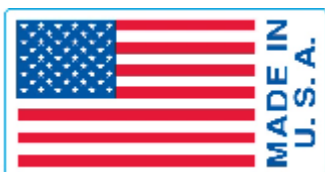

RIGID[®]
HITCH INCORPORATED
3301 WEST BURNSVILLE PARKWAY
BURNSVILLE, MN 55337

REV.
11/19