

**INSTALLATION INSTRUCTIONS  
WEIGHT DISTRIBUTING  
HITCH SYSTEM**

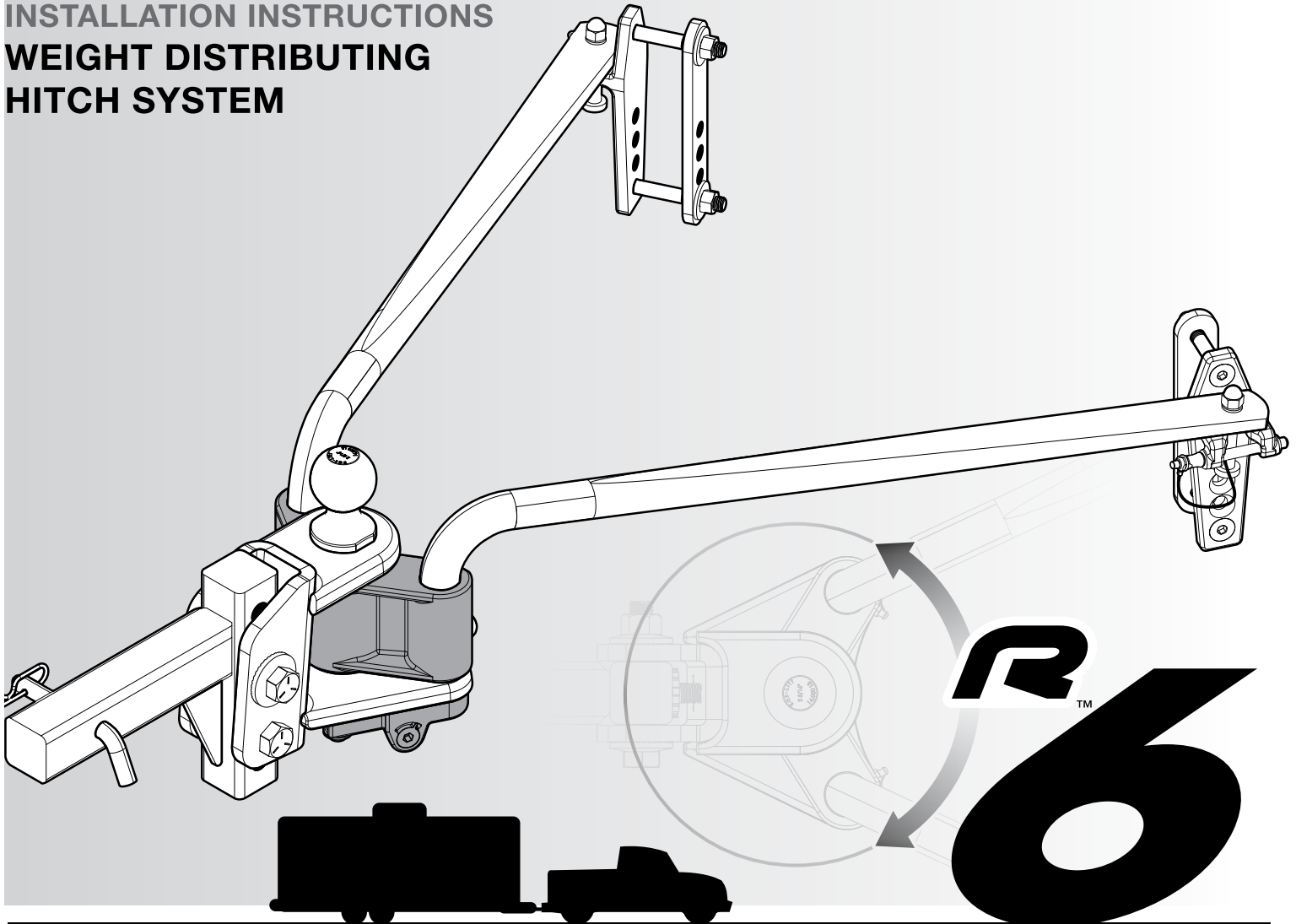

**Rating when used as a weight distributing hitch with spring bars:**

Part Number	Max Tongue Weight	Max Gross Trailer Weight
48731 <b>600 lb Hitch</b>	800 lb	8,000 lb
48733 <b>1,000 lb Hitch</b>	1,200 lb	12,000 lb
48734 <b>1,200 lb Hitch</b>	1,400 lb	14,000 lb

**CAUTION:** The tongue weight rating of the spring bars represents the capacity of a pair of bars, not an individual bar. Always use a pair of spring bars and be sure they are of the same weight rating.

**Dealer / Installer:** Be sure customer receives installation instructions after hitch has been installed.

Do NOT exceed the towing vehicle manufacturer's load rating.  
READ ALL INSTRUCTIONS AND CHECK PACKAGE CONTENTS BEFORE BEGINNING INSTALLATION

## INSTALLATION INSTRUCTIONS PARTS LIST

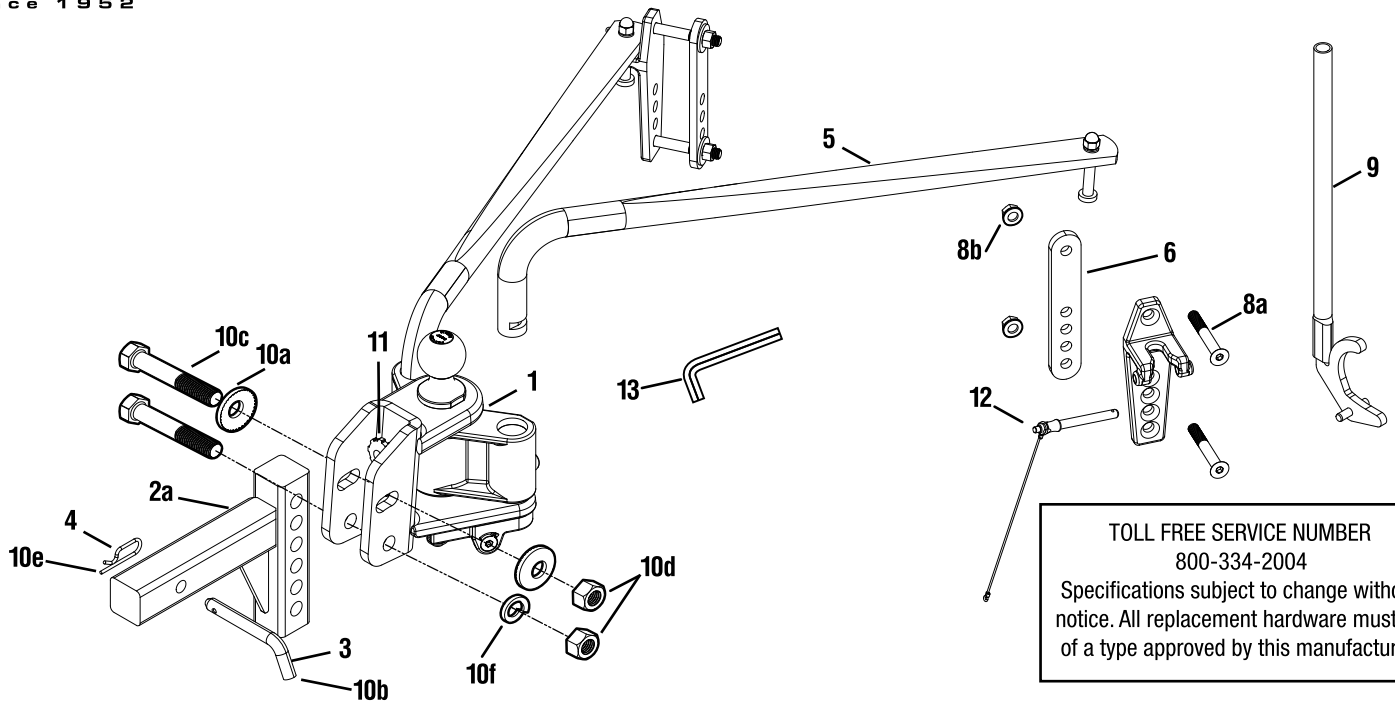

TOLL FREE SERVICE NUMBER  
800-334-2004  
Specifications subject to change without  
notice. All replacement hardware must be  
of a type approved by this manufacturer.

NO.	DESCRIPTION	PART NO.
1.	BALL MOUNT with ball for ReCurve R6 600-1,000-1,200	48736
2a.	ADJUSTABLE 2" SQUARE SHANK HI-LOW	
	10" length 3/4" Drop 7" Rise (Included)	48120
	12" length 3/4" Drop 7" Rise	48121
	14" length 3/4" Drop 7" Rise	48122
	16" length 3/4" Drop 7" Rise	48123
2b.	ADJUSTABLE SHANK EXTRA HI-LOW	
	2" square	
	10" length 4-1/4" Drop 10-1/4" Rise	48130
	12" length 4-1/4" Drop 10-1/4" Rise	48131
	14" length 4-1/4" Drop 10-1/4" Rise	48133
2c.	ADJUSTABLE SHANK EXTRA LOW	
	2" SQUARE	
	10" length 8" Drop	48132
3.	HITCH PIN	48021
4.	SPRING CLIP	48028
5.	SPRING BAR, ReCurve - (Set of 2)	
	600 lb rating	48737
	1,000 lb rating	48738
	1,200 lb rating	48739
6.	HOOK UP STRAP	48723
7.	HOOK UP HANGER, ReCurve R6 (Included)	48740
	HOOK UP HANGER, ReCurve R3/R6 for bottom mount coupler	48744

NO.	DESCRIPTION	PART NO.
8.	BOLT PACKAGE - HOOK UP, RECURVE	48741
	a. (4) each flat head screw, 1/2-13 X 3-3/4"	
	b. (4) each serrated flange nut, 1/2"-13	
9.	HOOK-UP TOOL	48742
10.	BOLT PACKAGE (for 600-1,000-1,200 Ball Mount)	48101
	a. (2) each 3/4" conical washer	
	b. (1) each hitch pin	
	c. (2) each bolt 3/4" - 10 x 4-1/2"	
	d. (2) each nuts 3/4"-10	
	e. (1) each spring clip	
	f. (1) each lock washer 3/4"	
11.	THUMBSCREW	48037
12.	PIN W/LANYARD - ReCurve R6	48743
13.	WRENCH, ALLEN, 8MM	48745



# INSTALLATION INSTRUCTIONS

## BALL MOUNT

**WARNING:** By towing a trailer you change the handling characteristics of the tow vehicle. Conditions you may encounter can cause sudden trailer sway. When used properly, the Eaz-Lift ReCurve Weight Distributing Hitch with Adaptive Sway Control dampens and reduces trailer sway and by distributing trailer tongue weight reduces unsafe towing vehicle handling. **IMPORTANT:** Short wheel base vehicles may induce sway when towing a trailer. USE EXTREME CAUTION.

To determine whether or not a particular tow vehicle and trailer combination is suitable, you should always refer to the driver's manual or user's manual provided by the vehicle and trailer manufacturers and seek the recommendations and advice of the trailer dealer. The United States Department of Transportation, the American Automobile Association, and various recreational vehicle associations and RV magazines also offer good advice on trailer towing practices.

- 1** The height of the ball must be determined before any assembly work can begin. The ReCurve hitch comes supplied with a pre-installed 2-5/16" hitch ball. To measure ball height, measure trailer from ground level to top of ball coupler. Be sure trailer is parallel to ground.

**For all tow vehicles** add approximately 1/8" for each 100 lb tongue weight. This will compensate for vehicle "squat."

**EXAMPLE:** If measured top of coupler height is 17" and trailer tongue weight (weight coupler would impose on ball) is 600 lb (6 x 1/8", = 3/4"). Therefore, 17" + 3/4" = 17-3/4" hitch setting height (to top of ball; assembled.)

- 2** After ball height has been determined: write down the ascertained height. Slide shank into sleeve receiver; insert hitch pin (48021) and spring clip (42028). Slide ball mount up or down shank (shank may be used in the up or down position) until nearest dimension is obtained and holes line up with shank. Insert bolt (10c) lock washer (10f), and nut (10d) in bottom hole, do not tighten (rest hitch head).

- 3** Thumbscrew (48037) is supplied in order to gain correct downward angle of spring bars. The thumbscrew is threaded into the 5/8" threaded hole in the "U" on ball mount. Begin with the top plate of the ball mount level with the ground as a starting point to determine spring bar angle. The spring bar angle will determine the weight distributing load transferred to the ballmount. Depending on angle or slope of bars that must be achieved, thread thumbscrew to the position necessary to establish correct angle for proper distribution of the tongue weight. (See Fig. 1, 2, and 3 below.) Angling the spring bars down will produce more

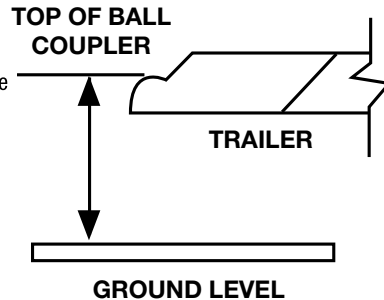

preload on the spring bars, thus distributing more of the tongue weight to the front axle of the tow vehicle. Conversely, angling the spring bars upward away from the ground will reduce the spring bar preload resulting in less of the tongue weight distributed to the front axle of the tow vehicle. The proper spring bar angle is achieved when both the tow vehicle and trailer are level with the ground. Applying excessive spring bar preload will result in an unbalanced load on the tow vehicle axles by distributing too much of the tongue weight to the front axle. Applying an insufficient amount of spring bar preload will result in an unbalanced load on the tow vehicle axles by applying too much of the tongue weight to the rear axle. Use thumbscrew and jack screw to temporary secure ball mount while determining spring bar angle.

- 4** To confirm the tongue weight is distributed evenly, measure the front and rear bumper heights prior to applying the trailer tongue weight and then again after the tongue weight has been applied with spring bars loaded. Both the front and rear dimensions should decrease approximately the same amount for a properly distributed load. If the difference in the bumper height change is greater than the 1", the spring bar pre-load should be adjusted accordingly. To make hooking up easier and safer-raise front of trailer and back of towing vehicle above level using trailer tongue jack. This removes some of the tension by reducing the distance between Spring Bar and Hook-Up Hanger.

Once the desired spring bar angle has been achieved, insert top bolt (10c) with serrated washer (10a). Install second serrated washer and nut (10d) to secure unit in correct position. Before tightening bolts, lock set screw. Tighten the 3/4" top bolt to 260 ft. lbs torque once head angle is set. Tighten lower bolt to 260 ft. lbs torque. After first day of towing, check set screw for tightness.

**CAUTION:** Do not adjust air shocks or air bags to support any of the tongue weight of trailer. Air shocks or air bags should only be used to support the added weight you load in the rear of tow vehicle.

Fig. 1

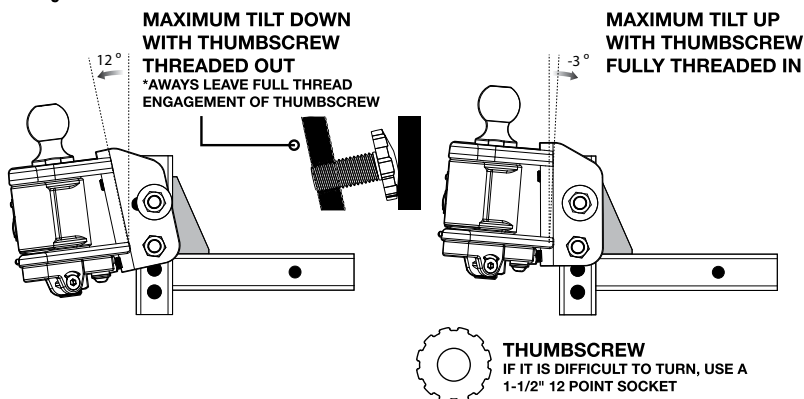

Fig. 2

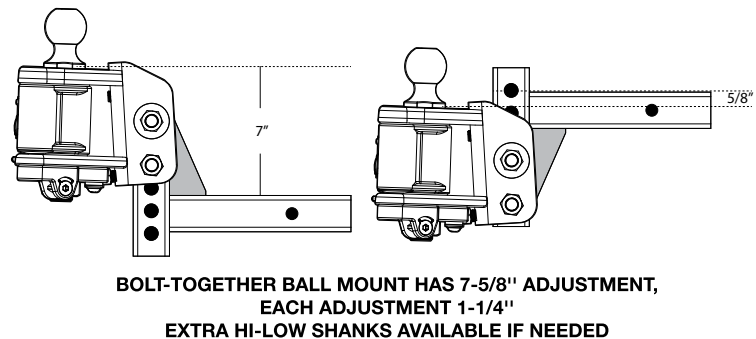
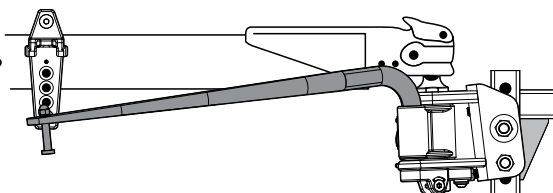
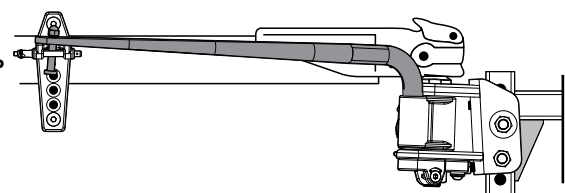

Fig. 3

**BEFORE HOOKING UP** Spring bars should slope on the angle determined by the thumbscrew. See Step 3.



**AFTER HOOKING UP** Spring bar should be parallel with trailer frame.



# INSTALLATION INSTRUCTIONS

## HOOK-UP BRACKETS

**1** The Spring Bars can be inserted into either side of Ball Mount (there is no 'right' or 'left bar'). Insert Spring Bar in Ball Mount socket, the Spring Bar will automatically lock in position by the Spring Bar Locking Device. (Check to make sure bar is locked in by moving it up and down at the end.) To remove Spring Bars, swing bar around parallel with bumper to disengage Locking Device and then lift Spring Bar from Ball Mount.

**2** Position the Hook Up Hanger centerline 32" from the center of the coupler ball socket. The Hook Up Hanger must be installed at this location to ensure proper alignment of the trunnion and sway control mechanism. To confirm the location of the Hookup Hangers, position the tow vehicle and trailer in a straight-line. Rotate the stud end of the Spring Bar to the slot in Hook Up Hanger. The Spring Bar Stud should locate in the slot of the Hook Up Hanger in approximately the same position on each side. If both sides do not locate correctly, check the Hook Up Hanger position and confirm the trunnion is located in a straight-line orientation.

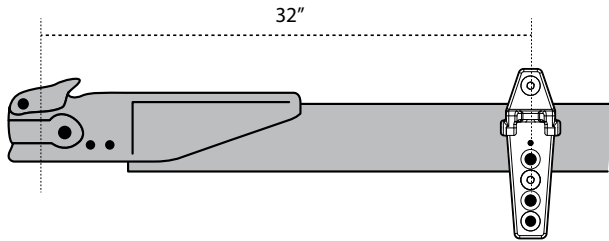

**3** Once the correct location is determined, insert the supplied 1/2" flat head screws into the corresponding holes of the Hook Up Hanger determined by the height of the trailer frame. Place the Hook Up Strap on the opposing side of the trailer frame and align the corresponding holes with the 1/2" flat head screws. Install the supplied 1/2" serrated flanged nuts. Do not tighten. Snug nuts so that Hook Up Hanger is held in position but can still slide on the trailer frame. For bottom mount coupler use #48740 Hook Up Hanger.

The height of the Hook Up Hanger is predetermined to ensure spring bars are level. Additional preload of the spring bar should be achieved by adjusting the tilt of the ballmount using thumbscrew.

**4** Load Spring Bar to confirm Hook Up Hanger orientation. (See Fig. 1) To load Spring Bar onto Hook Up Hanger insert pivot pin of Hook Up Tool into pivot hole of Hook Up Hanger. Position Spring Bar in throat of Hook Up Tool and rotate Hook Up Tool handle upward until Spring Bar seats on Hook Up Hanger. The Spring Bar Stud should align with slot in Hook Up Hanger. If Spring Bar Stud does not freely fall into Hook Up Hanger Slot, check Hook Up Hanger placement on trailer frame and confirm sway control function has been disabled. To secure Spring Bar, insert pin (#48743) through pivot hole of Hook Up Hanger. Once loaded the Hook Up Hanger should rotate to accommodate the angled bottom of the Spring Bar. Ensure bottom of spring bar is in contact with the Hook Up Hanger across the entire width. Ensure Spring Bar Stud is in the center of each Hook Up Hanger and the Ball Mount is centered. Re-measure distance from center of coupler to center of Hook Up Hanger. Confirm the dimension is the same for both sides. If not the same, reposition Hook Up Hanger and confirm Spring Bar Stud is still located in the center of the Hook Up Hanger Slot. Tighten to secure the Hook Up Hanger to the trailer frame. Tighten the nuts in an alternating pattern to ensure Hook Up Hanger and Hook Up Strap are squarely clamped on the trailer frame.

Fig. 1

Fig. 2

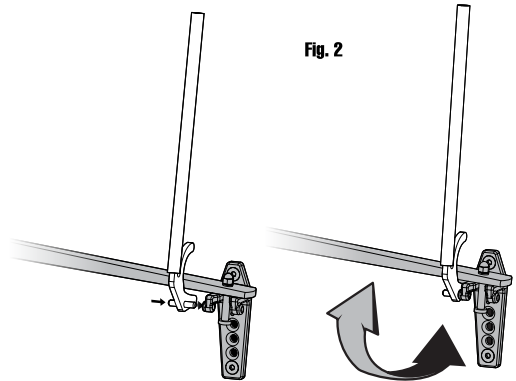

Fig. 3

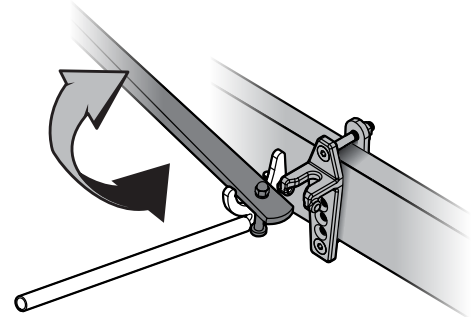
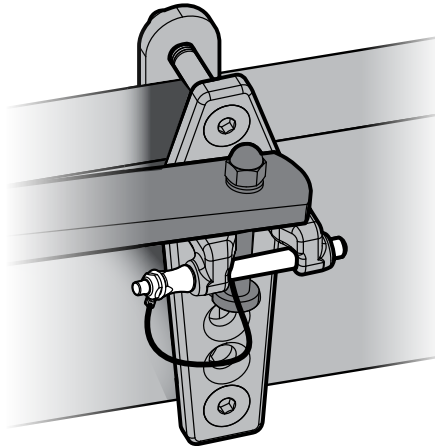

Fig. 4



**5** To release tension on spring bars, raise front of trailer and back of towing vehicle above level (approx. 3") using trailer tongue jack. Remove Pin (#48743). Insert Hook Up Tool pivot pin into pivot hole of Hook Up Hanger with the Spring Bar positioned in the throat of the Hook Up Tool. Carefully rotate Hook Up Tool downward until Spring Bar pre-load is relieved. Remove Hook Up Tool from Hook Up Hanger.



# RECURVE R6™ Adaptive Sway Control Weight Distributing Hitch

The ReCurve R6 uses an Innovative Adaptive Sway Technology System to improve the safety and handling characteristics of your trailer and tow vehicle combination.

The basis of this Adaptive Sway Technology is the linear increase in sway resistance proportional to the angular rotation of the trailer about the hitch ball. When the ReCurve R6 encounters a sway situation the adaptive system combats the trailer sway with an increasing resistance to dampen any oscillations and return the trailer and tow vehicle to a safe straight line configuration. The advantage of the adaptive system is that it prevents the traditional 'tight' setup of conventional sway control hitches. Rather than 'locking' the tow vehicle and trailer into a straight line to prevent sway, the ReCurve R6 allows for adaptive abatement which greatly improves the handling characteristics of the rig.

Conventional integrated sway control hitches provide a constant resistance to rotation through the entire range of motion of the tow vehicle and trailer setup. This configuration produces a 'tight' handling characteristic even when the sway abatement is not required. The ReCurve R6 addresses this issue by not only building the sway resistance adaptively as needed, but the ReCurve R6 also automatically disengages itself for maneuvering.

The end result of the Adaptive Sway Technology System is that sway abatement only occurs when it is needed and adaptively increases this resistance to prevent sway.

With the ReCurve R6 you also have the option to disengage the sway control function to prevent any unsafe maneuvering situations in adverse weather conditions such as slippery road surfaces.

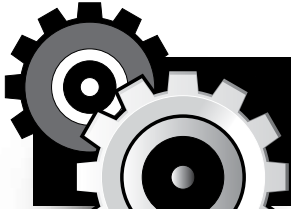

## INSTALLATION INSTRUCTIONS HOW-TO-USE



### Activating the Adaptive Sway System

The ReCurve R6 is factory pre-calibrated for optimal sway control performance. The Activation Cams engage and disengage the Adaptive Sway System. To engage the sway control function rotate the Activation Cam clockwise using the included hex key wrench. It is recommended to park the tow vehicle and trailer in an angled configuration to reduce the torque required to rotate the Activation Cam.

Once the tow vehicle and trailer setup returns to a straight line orientation, the sway control function will self engage.

### Disengaging the adaptive sway system

To disengage the sway control function rotate the Activation Cam counterclockwise using the included hex key wrench. It is recommended to park the tow vehicle and trailer in an angled configuration to reduce the torque required to rotate the Activation Cam.

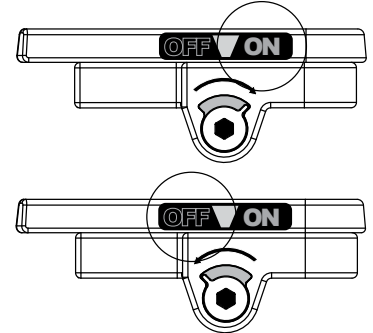
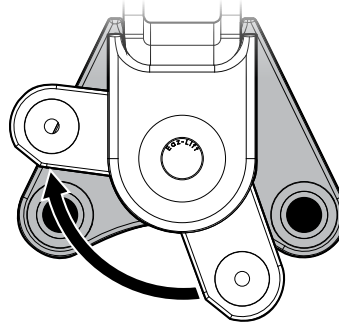

### Storage of the ReCurve R6 Hitch

It is recommended that the hitch be stored in an area protected from environmental elements when not in use. The ReCurve R6 should also be stored with the preload removed from the adaptive sway system. To remove the preload repeat the disengagement steps.

### ReCurve Maintenance

The ReCurve Hitch requires lubrication of the trunnion spindle and the two engagement ball guides. The trunnion spindle is easily serviceable using the factory installed grease fitting.

Engagement ball and guide lubrication: Disengage the Adaptive Sway System. Rotate the trunnion so the engagement balls and guides are visible. Apply wheel bearing grease to the surface of the engagement ball. Rotate the engagement balls while applying grease to work grease into the pocket of the ball guide. Prior to each use ensure that these three critical areas have been sufficiently lubricated.



## LIMITED WARRANTY

This Warranty applies solely to the Weight Distributing Hitch (the "Product") manufactured by Camco Manufacturing, Inc. ("Camco")

1. **Warranty and Warranty Period.** Camco warrants to the Product's original purchaser or consumer (the "Purchaser") that the Product will be free of defects in manufacture and workmanship for a period of 5 Years from the date of consumer purchase or Camco will replace the Product free of charge (the "Warranty"). This Warranty is non-transferrable and applies only to the original vehicle on which the Product was installed.
2. **Limitations on the Warranty.** This Warranty does not cover the following: (a) normal wear and tear; (b) service or labor charges which are incurred in removing or replacing any Product; (c) the finish placed on the Product; (d) Product damage or failure which occurs as a result of abuse, neglect or misuse in any manner; and (e) damage which occurs to a Product that is misapplied, overloaded, improperly installed, or altered in any manner by anyone other than Camco.
3. **Obligation of Purchaser.** To obtain the benefits of this Warranty, the Purchaser must complete the following steps: **(a) fill out online Warranty Registration within 10 days of purchase at [www.camco.net/warranty](http://www.camco.net/warranty)**; (b) promptly present the defective Product together with the proof of purchase to Camco located at 121 Landmark Drive, Greensboro, NC 27409 and (c) pay all handling, transportation, and shipping charges incurred for the return of the defective Product. Any defective Product returned to Camco shall become the property of Camco.
4. **Obligations of Camco.** Subject to the terms and limitations set forth in this Warranty, Camco's sole obligation will be to replace for the original Purchaser free of charge any Product that is found to be defective.
5. **Legal Rights.** THIS WARRANTY GIVES YOU SPECIFIC LEGAL RIGHTS AND YOU MAY ALSO HAVE OTHER RIGHTS WHICH VARY FROM STATE TO STATE. CAMCO MAKES NO EXPRESSED OR IMPLIED WARRANTY OF MERCHANTABILITY OR FITNESS FOR A PARTICULAR PURPOSE. SOME STATES DO NOT ALLOW LIMITATIONS ON HOW LONG AN IMPLIED WARRANTY LASTS, SO THE ABOVE LIMITATIONS MAY NOT APPLY TO YOU. CAMCO ASSUMES NO LIABILITY OR RESPONSIBILITY FOR BODILY INJURY THAT MAY BE INFLICTED ON THE PURCHASER, OPERATOR, SPECTATOR OR GENERAL PUBLIC WHO IS IN THE GENERAL AREA WHILE THIS EQUIPMENT IS IN USE, FOR THE LOSS OF THE USE OF ANY VEHICLE, LOSS OF TIME, RENTAL OF VEHICLES, LOSS OR DAMAGE TO PERSONAL PROPERTY, EXPENSES SUCH AS GASOLINE, TELEPHONE, LODGING, OR TOWING, OR ANY OTHER INCIDENTAL OR CONSEQUENTIAL DAMAGES INCURRED AS A RESULT OF THE USE OR OWNERSHIP OF ANY PRODUCT. SOME STATES DO NOT ALLOW THE EXCLUSION OF A LIMITATION OF INCIDENTAL OR CONSEQUENTIAL DAMAGES, SO THE EXCLUSION OR LIMITATION SET FORTH MAY NOT APPLY TO YOU. REPLACEMENT OF THE PRODUCT IN THE MANNER PROVIDED ABOVE SHALL CONSTITUTE FULFILLMENT OF ALL LIABILITIES OF CAMCO TO THE PURCHASER WHETHER BASED ON CONTRACT OR OTHERWISE.

CAMCO RESERVES THE RIGHT TO MAKE CHANGES IN DESIGN OR TO MAKE ADDITIONS OR IMPROVEMENTS WITHOUT BEING OBLIGATED TO INSTALL THE SAME UPON PRODUCTS COVERED BY THIS WARRANTY. THIS WARRANTY IS VALID ONLY IN THE UNITED STATES AND CANADA.

### CAMCO MFG., INC.

121 Landmark Drive / Greensboro, NC 27409 / USA

1-800-334-2004

[www.eaz-lift.com](http://www.eaz-lift.com)

