

**INSTALLATION INSTRUCTIONS
WEIGHT DISTRIBUTING
HITCH SYSTEM**

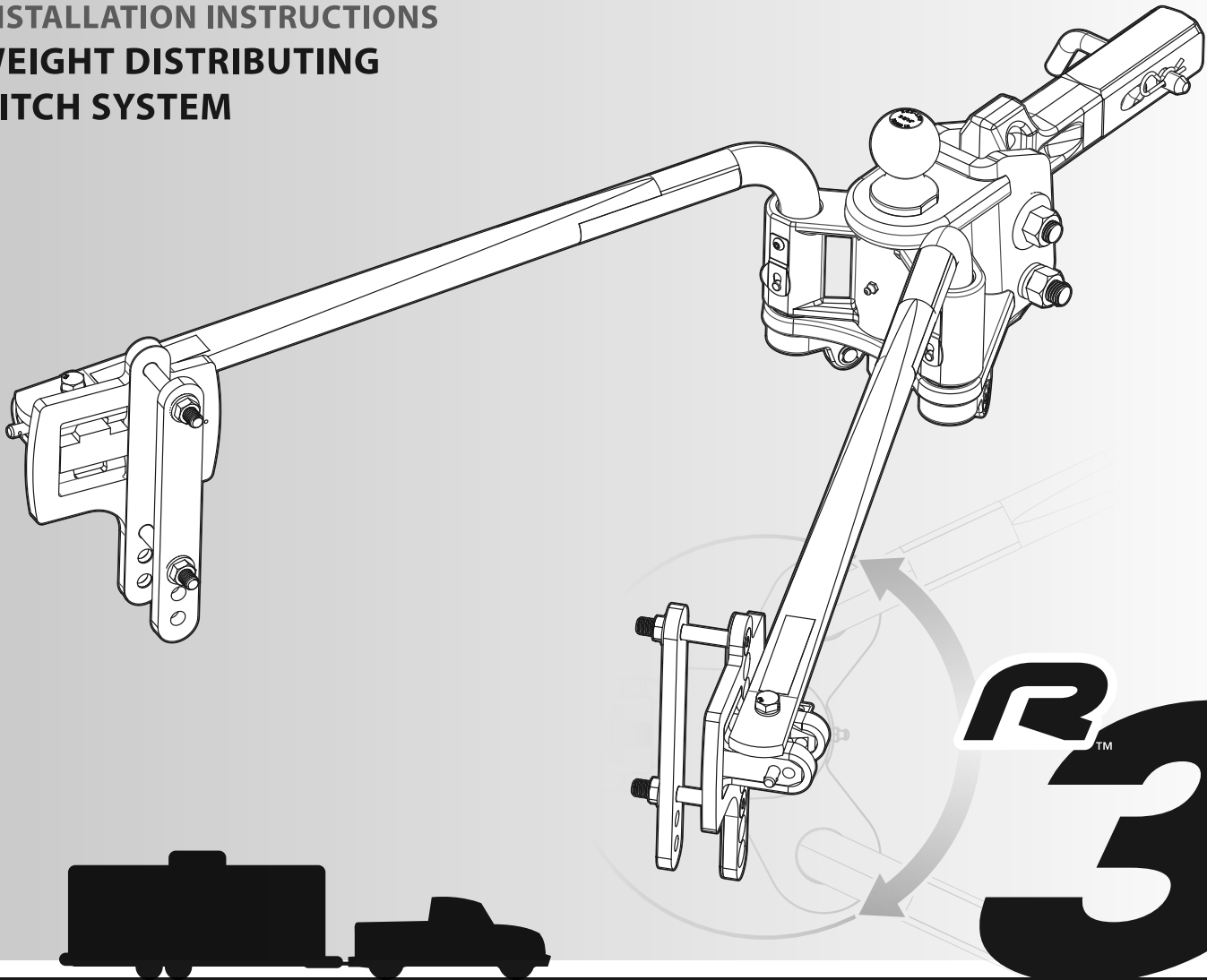

Rating when used as a weight distributing hitch with spring bars:

| Part Number | Max Tongue Weight | Max Gross Trailer Weight |
|-----------------------------|-------------------|--------------------------|
| 48753 1,200 lb Hitch | 1,500 lb | 15,000 lb |

CAUTION: The tongue weight rating of the spring bars represents the capacity of a pair of bars, not an individual bar. Always use a pair of spring bars and be sure they are of the same weight rating.

WARNING: Disable tow vehicle's electronic sway control when a hitch with built-in sway control is in use.

Dealer / Installer: Be sure customer receives installation instructions after hitch has been installed.

Do NOT exceed the towing vehicle manufacturer's load rating.
READ ALL INSTRUCTIONS AND CHECK PACKAGE CONTENTS
BEFORE BEGINNING INSTALLATION

www.eaz-lift.com

CAMCO PRINTING INFORMATION
(Do not Print)

Item Name: ReCurve R3 Instructions
New RM#: CD895123
Old RM#: CD895113
Drawing #: 1019665
Colors: 1/1
Coating: None
Size: 8.5" x 11"
Stock: 60# Text Paper (89 grams)
UPC: None
Notes: N/A
Rev #: 1
Date Released: 6/19

ESKO
Dieline Key
Cut Line
Crease Line
Perforated Line
Glue Area
PSL
CutContour

No intentional introduction of Lead (Pb), Cadmium (Cd), Hexavalent Chrome and Mercury (Hg) allowed in manufacture of this packaging material. The sum of the concentration levels incidentally introduced not to exceed 100 PPM by weight.

INSTALLATION INSTRUCTIONS
PARTS LIST

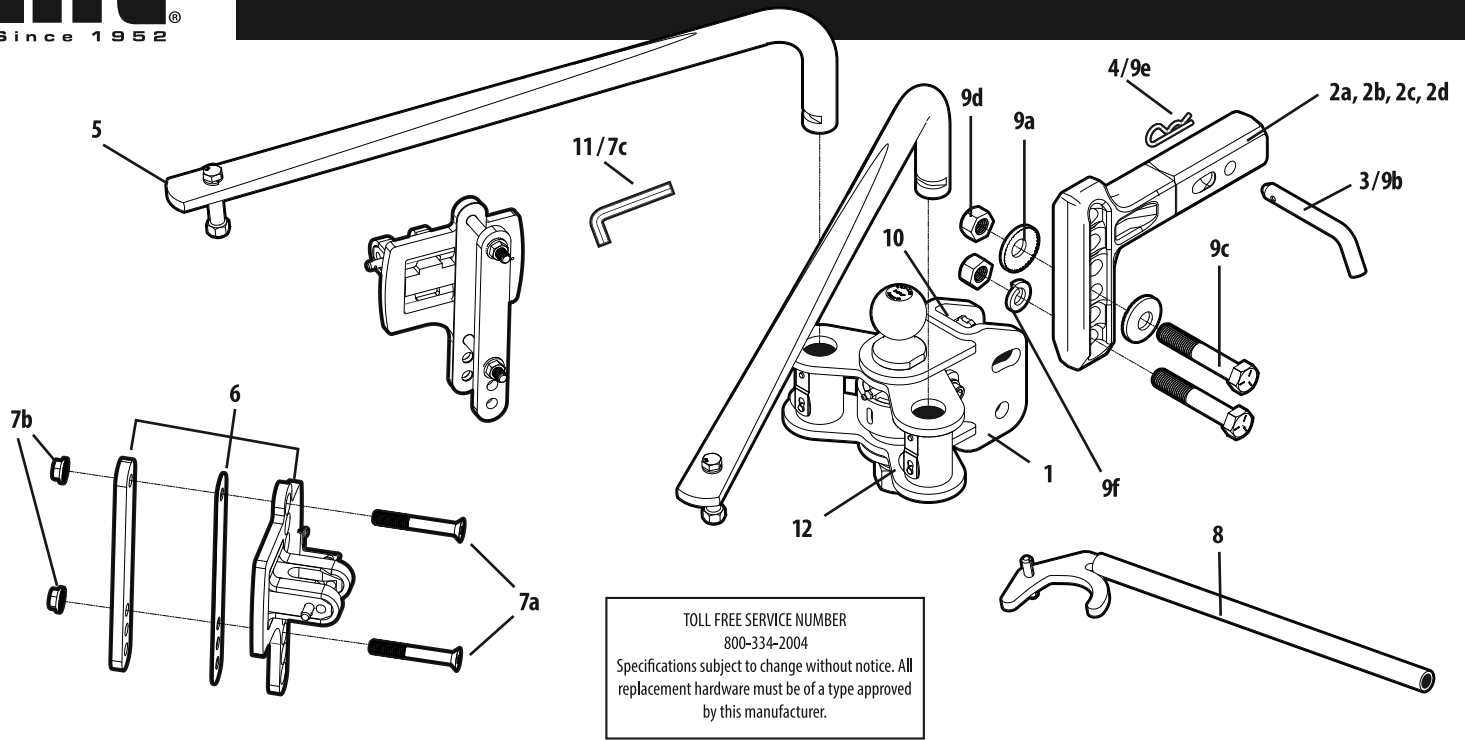

TOLL FREE SERVICE NUMBER
800-334-2004
Specifications subject to change without notice. All replacement hardware must be of a type approved by this manufacturer.

| NO. | DESCRIPTION | PART NO. |
|-----|--|----------------------------------|
| 1. | BALL MOUNT with ball for ReCurve R3 400-600-1,000-1,200 | 48755 |
| 2a. | ADJUSTABLE 2" SQUARE SHANK HI-LOW 12" length (Included) 14" length 16" length 18" length | 48650 48121 48122 48123 |
| 2b. | ADJUSTABLE 2" SQUARE SHANK EXTRA HI-LOW (Additional 3.25" drop/rise) 12" length 14" length 16" length | 48653 48131 48133 |
| 2c. | ADJUSTABLE 2" SQUARE SHANK EXTRA LOW 12" length 9" Drop | 48132 |
| 2d. | ADJUSTABLE 2.5" SQUARE SHANK 12" length | 48651 |
| 2e. | ADJUSTABLE 2.5" SQUARE SHANK EXTRA HI-LOW (Additional 3.25" drop/rise) 12" length | 48652 |
| 3. | HITCH PIN | 48021 |
| 4. | SPRING CLIPS (PAIR) | 48766 |
| 5. | SPRING BAR, ReCurve - (Set of 2) 1,200 lb rating | 48739 |

| NO. | DESCRIPTION | PART NO. |
|-----|---|----------------|
| 6. | HOOK UP HANGER KIT - 3-6" FRAME HOOK UP HANGER KIT - 6-8" FRAME (Included) | 48749 48781 |
| 7. | BOLT PACKAGE - HOOK UP, RECURVE, R3 a. (4) each flat head screw, 1/2-13 X 3-3/4" b. (4) each serrated flange nut, 1/2"-13 c. (1) allen wrench (10 mm) | 48757 |
| 8. | HOOK-UP TOOL | 48742 |
| 9. | BOLT PACKAGE - RECURVE a. (2) each 3/4" conical washer b. (1) each hitch pin c. (2) each bolt 3/4"- 10 x 4-1/2" d. (2) each nuts 3/4"-10 e. (1) each spring clip f. (1) each lock washer 3/4" | 48765 |
| 10. | THUMBSCREW | 48037 |
| 11. | WRENCH, ALLEN, 10MM | 48758 |
| 12. | SPRING BAR LOCKING DEVICE REPAIR KIT | 48104 |



INSTALLATION INSTRUCTIONS

BALL MOUNT

WARNING: By towing a trailer you change the handling characteristics of the tow vehicle. Conditions you may encounter can cause sudden trailer sway. When used properly, the Eaz-Lift ReCurve Weight Distributing Hitch with Sway Control dampens and reduces trailer sway and by distributing trailer tongue weight reduces unsafe towing vehicle handling. **IMPORTANT:** Short wheel base vehicles may induce sway when towing a trailer. **USE EXTREME CAUTION.**

To determine whether or not a particular tow vehicle and trailer combination is suitable, you should always refer to the driver's manual or user's manual provided by the vehicle and trailer manufacturers and seek the recommendations and advice of the trailer dealer.

The United States Department of Transportation, the American Automobile Association, and various recreational vehicle associations and RV magazines also offer good advice on trailer towing practices.

1 The height of the ball must be determined before any assembly work can begin. The ReCurve hitch comes supplied with a pre-installed 2-5/16" hitch ball. To measure ball height, measure trailer from ground level to top of ball coupler. Be sure trailer is parallel to ground. **For all tow vehicles** add approximately 1/8" for each 100 lb tongue weight. This will compensate for vehicle "squat."

EXAMPLE: If measured top of coupler height is 17" and trailer tongue weight (weight coupler would impose on ball) is 600 lb (6 x 1/8", = 3/4"). Therefore, 17" + 3/4" = 17-3/4" hitch setting height (to top of ball; assembled.)

2 After ball height has been determined: write down the ascertained height. Slide shank into sleeve receiver; insert hitch pin (48021) and spring clip (48766). Slide ball mount up or down shank (shank may be used in the up or down position) until nearest dimension is obtained and holes line up with shank. Insert bolt (9c) lock washer (9f), and nut (9d) in bottom hole, do not tighten (rest hitch head).

3 Thumbscrew (48037) is supplied in order to gain correct downward angle of spring bars. The thumbscrew is threaded into the 5/8" threaded hole in the "U" on ball mount. Begin with the top plate of the ball mount level with the ground as a starting point to determine spring bar angle. The spring bar angle will determine the weight distributing load transferred to the ball mount. Depending on angle or slope of bars that must be achieved, thread thumbscrew to the position necessary to establish correct angle for proper distribution of the tongue weight. (See Fig. 1, 2, and 3 below.)

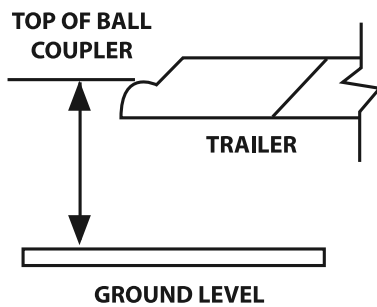

Angling the spring bars down will produce more preload on the spring bars, thus distributing more of the tongue weight to the front axle of the tow vehicle. Conversely, angling the spring bars upward away from the ground will reduce the spring bar preload resulting in less of the tongue weight distributed to the front axle of the tow vehicle. The proper spring bar angle is achieved when both the tow vehicle and trailer are level with the ground. Applying excessive spring bar preload will result in an unbalanced load on the tow vehicle axles by distributing too much of the tongue weight to the front axle. Applying an insufficient amount of spring bar preload will result in an unbalanced load on the tow vehicle axles by applying too much of the tongue weight to the rear axle. Use thumbscrew and jack screw to temporarily secure ball mount while determining spring bar angle.

4 To confirm the tongue weight is distributed evenly, measure the front and rear bumper heights prior to applying the trailer tongue weight and then again after the tongue weight has been applied with spring bars loaded. Both the front and rear dimensions should decrease approximately the same amount for a properly distributed load. If the difference in the bumper height change is greater than the 1", the spring bar pre-load should be adjusted accordingly. To make hooking up easier and safer-raise front of trailer and back of towing vehicle above level using trailer tongue jack. This removes some of the tension by reducing the distance between Spring Bar and Hook-Up Hanger.

Once the desired spring bar angle has been achieved, insert top bolt (9c) with serrated washer (9a). Install second serrated washer and nut (9d) to secure unit in correct position. Before tightening bolts, lock set screw. Tighten the 3/4" top bolt to 260 ft lb torque once head angle is set. Tighten lower bolt to 260 ft lb torque. After first day of towing, check set screw for tightness.

CAUTION: Do not adjust air shocks or air bags to support any of the tongue weight of trailer. Air shocks or air bags should only be used to support the added weight you load in the rear of tow vehicle.

Fig. 1

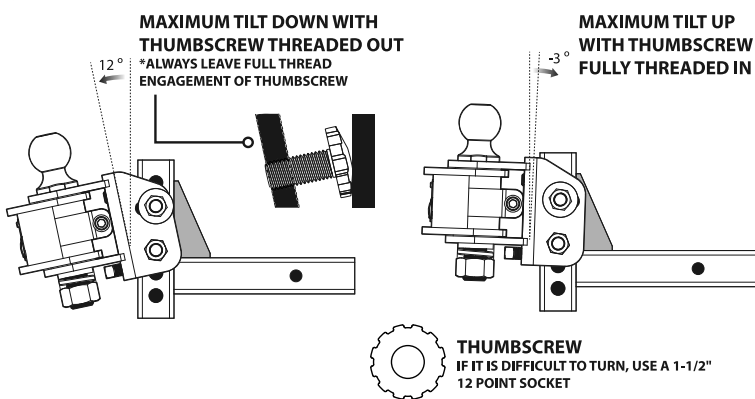

Fig. 2

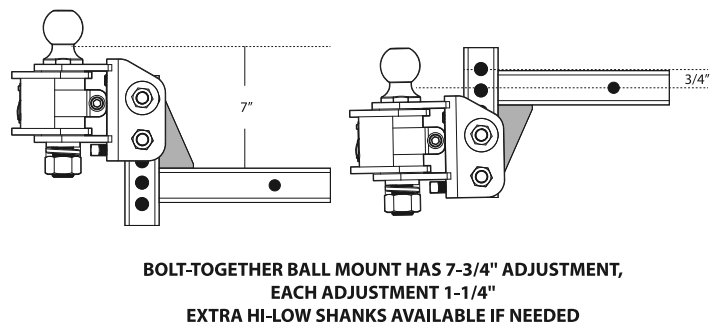
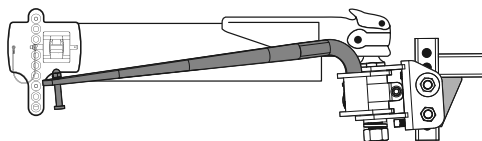
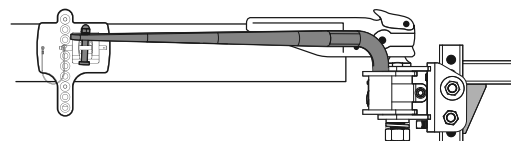

Fig. 3

BEFORE HOOKING UP
Spring bars should slope on the angle determined by the thumbscrew. See Step 3.



AFTER HOOKING UP
Spring bar should be parallel with trailer frame.



www.eaz-lift.com

INSTALLATION INSTRUCTIONS

HOOK-UP BRACKETS

1

The Spring Bars can be inserted into either side of Ball Mount (there is no 'right' or 'left bar'). Insert Spring Bar in Ball Mount socket, the Spring Bar will automatically lock in position by the Spring Bar Locking Device. (Check to make sure bar is locked in by moving it up and down at the end.) To remove Spring Bars, swing bar around parallel with bumper to disengage Locking Device and then lift Spring Bar from Ball Mount.

2

With the tow vehicle coupled to the ball mount and the sway control turned off, position the Spring Bars alongside the trailer frame. Rotate the trunnion such that it is aligned squarely with the trailer and the Spring Bar Studs are of equal distance to the center of the ball. (See Fig. 1)

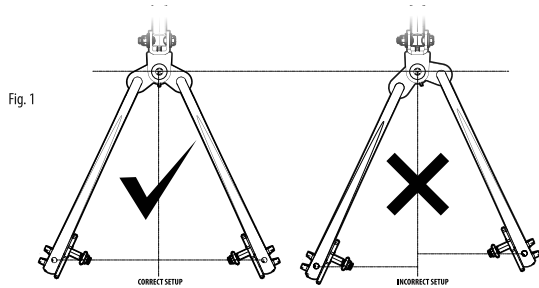

With the Spring Bars in the correct position, the Spring Bar Studs can be used to reference the approximate mounting location of the Hook-up Bracket along the frame.

The Hook-up Brackets are designed with a 2" offset from the center of the frame clamping location to the center of the channel and platform that accepts the spring bar. The offset direction of the two supplied Hook-up Brackets are opposite of one another which allows for the clamping portion of the Hook-up Bracket to be installed on the trailer frame 2" in front or 2" behind the location of the Spring Bar Stud to avoid interference with existing items that may be attached to the trailer frame. (See Fig. 6) The included Hook-up Brackets can also be inverted for use with bottom mount coupler designed trailers. Determine which offset location is needed or preferred and install the brackets on the appropriate side of the trailer frame. (See Fig. 6)

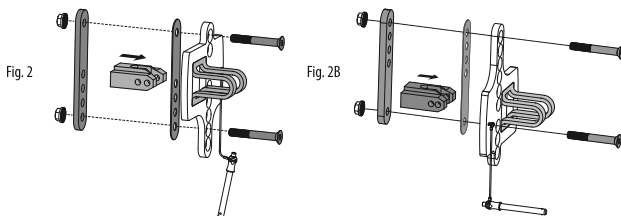

3

- Install the Hook-up Bracket Insert into the Hook-up Bracket such that the raised boss faces upward. (See Fig. 2)
- Insert the supplied 1/2" flat head screws into the corresponding holes of the Hook-up Bracket determined by the height of the trailer frame and the required orientation (top or bottom mount coupler). (See Fig. 2)
- Install the Hook-up Bracket Spacer onto the 1/2" flat head screws such that it rests against the back of the Hook-up Bracket. The Hook-up Bracket Spacer will be captured between the Hook-up Bracket and the trailer frame when the installation is complete. Place the Hook-up Strap on the opposing side of the trailer frame and align the corresponding holes with the 1/2" flat head screws. Install the supplied 1/2" serrated flanged nuts. Do not tighten. Snug nuts so that the Hook-up Bracket is held in position but can still slide on the trailer frame. (See Fig. 2)
- The height of the Hook-up Bracket is predetermined to ensure the Spring Bars are level. Additional preload of the Spring Bars should be achieved by adjusting the tilt of the Ball Mount using the thumbscrew.

Fig. 3

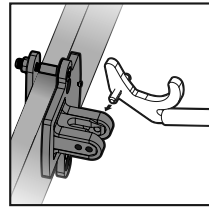

Fig. 4

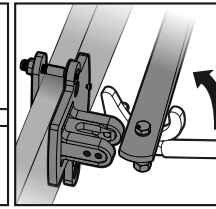

Fig. 5

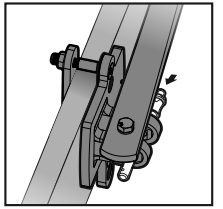
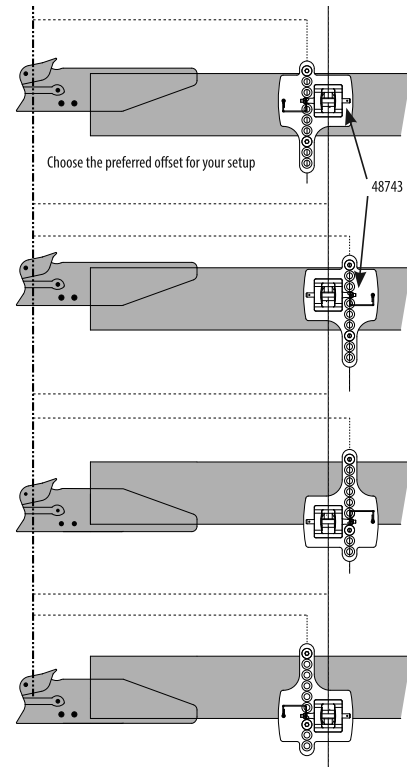

Fig. 6



4

Load Spring Bar to confirm Hook Up Hanger orientation. (See Fig. 3-5) To load Spring Bar onto Hook Up Hanger insert pivot pin of Hook Up Tool into pivot hole of Hook Up Hanger. Position Spring Bar in throat of Hook Up Tool and rotate Hook Up Tool handle upward until Spring Bar seats on Hook Up Hanger. The Spring Bar Stud should align with slot in Hook Up Hanger. If Spring Bar Stud does not freely fall into Hook Up Hanger Slot, check Hook Up Hanger placement on trailer frame and confirm sway control function has been disabled. To secure Spring Bar, insert pin (#48743) through pivot hole of Hook Up Hanger. Once loaded the Hook Up Hanger should rotate to accommodate the angled bottom of the Spring Bar. Ensure bottom of spring bar is in contact with the Hook Up Hanger across the entire width. Ensure Spring Bar Stud is in the center of each Hook Up Hanger and the Ball Mount is centered. Re-measure distance from center of coupler to center of Hook Up Hanger. Confirm the dimension is the same for both sides. If not the same, reposition Hook Up Hanger and confirm Spring Bar Stud is still located in the center of the Hook Up Hanger Slot. Tighten to secure the Hook Up Hanger to the trailer frame. Tighten the nuts in an alternating pattern to ensure Hook Up Hanger and Hook Up Strap are squarely clamped on the trailer frame.

5

To release tension on spring bars, raise front of trailer and back of towing vehicle above level (approximately 3") using trailer tongue jack. Remove Pin (#48743). Insert Hook Up Tool pivot pin into pivot hole of Hook Up Hanger with the Spring Bar positioned in the throat of the Hook Up Tool. Carefully rotate Hook Up Tool downward until Spring Bar pre-load is relieved. Remove Hook Up Tool from Hook Up Hanger.

www.eaz-lift.com

RECURVE R3™ with Sway Control Weight Distributing Hitch



The ReCurve R3 uses an Adjustable Sway Control System to improve the safety and handling characteristics of your trailer and tow vehicle combination.

The ReCurve R3 provides constant sway resistance through an entire range of angular rotation. The consistent sway resistance is achieved by the sway control clamp which allows the user to determine the magnitude of the sway resistance required. Unlike other sway control weight distribution hitches, the R3 sway resistance is achieved independently of the trailer tongue weight - allowing the user infinite adjustment between zero sway control and the factory preset maximum sway resistance. The axis of rotation of the sway control clamp is the same axis as the hitch ball which

allows for a direct application of the sway resistance rather than relying on the transmission of resistive forces by external components.

With the ReCurve you also have the option to disengage the sway control function to prevent any unsafe maneuvering situations in adverse weather conditions which may produce slippery road surfaces.

WARNING: Disable tow vehicle's electronic sway control when a hitch with built-in sway control is in use.

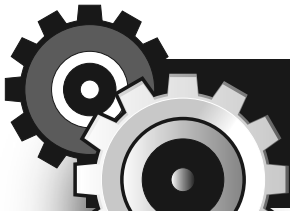

INSTALLATION INSTRUCTIONS HOW-TO-USE

■ Activating the Sway Control System

Activation of the sway control is easy - simply tighten the activation bolt until the desired sway resistance is achieved. [use 48758 wrench (11,7c)]

■ Disengaging the Sway Control System for hook up and travel in adverse road conditions

To disengage the sway control function - Loosen the activation bolt until the clamp force is removed.

■ Storage of the ReCurve R3 Hitch

It is recommended that the hitch be stored in an area protected from environmental elements when not in use. The ReCurve R3 should also be stored with the preload removed from the sway control system. To remove the preload repeat the disengagement steps outlined above.

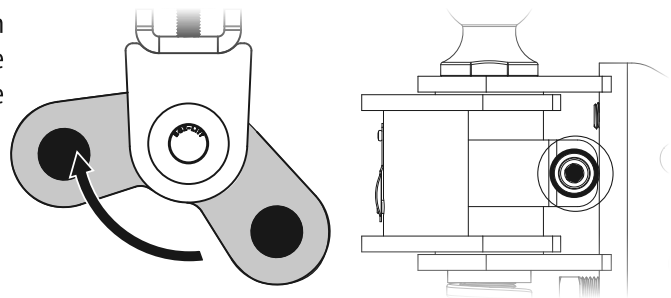

ReCurve Maintenance

The ReCurve R3 Hitch requires lubrication of the trunnion spindle. The trunnion spindle is easily serviceable using the factory installed grease fitting. Prior to each use ensure this critical area has been sufficiently lubricated with a suitable wheel bearing grease.



www.eaz-lift.com

LIMITED WARRANTY

This Warranty applies solely to the Weight Distributing Hitch (the "Product") manufactured by Camco Manufacturing, Inc. ("Camco")

1. **Warranty and Warranty Period.** Camco warrants to the Product's original purchaser or consumer (the "Purchaser") that the Product will be free of defects in manufacture and workmanship for a period of 5 Years from the date of consumer purchase or Camco will replace the Product free of charge (the "Warranty"). This Warranty is non-transferrable and applies only to the original vehicle on which the Product was installed.
2. **Limitations on the Warranty.** This Warranty does not cover the following: (a) normal wear and tear; (b) service or labor charges which are incurred in removing or replacing any Product; (c) the finish placed on the Product; (d) Product damage or failure which occurs as a result of abuse, neglect or misuse in any manner; and (e) damage which occurs to a Product that is misapplied, overloaded, improperly installed, or altered in any manner by anyone other than Camco.
3. **Obligation of Purchaser.** To obtain the benefits of this Warranty, the Purchaser must complete the following steps: **(a) fill out online Warranty Registration within 10 days of purchase at www.camco.net/warranty;** (b) promptly present the defective Product together with the proof of purchase to Camco located at 121 Landmark Drive, Greensboro, NC 27409 and (c) pay all handling, transportation, and shipping charges incurred for the return of the defective Product. Any defective Product returned to Camco shall become the property of Camco.
4. **Obligations of Camco.** Subject to the terms and limitations set forth in this Warranty, Camco's sole obligation will be to replace for the original Purchaser free of charge any Product that is found to be defective.
5. **Legal Rights.** THIS WARRANTY GIVES YOU SPECIFIC LEGAL RIGHTS AND YOU MAY ALSO HAVE OTHER RIGHTS WHICH VARY FROM STATE TO STATE. CAMCO MAKES NO EXPRESSED OR IMPLIED WARRANTY OF MERCHANTABILITY OR FITNESS FOR A PARTICULAR PURPOSE. SOME STATES DO NOT ALLOW LIMITATIONS ON HOW LONG AN IMPLIED WARRANTY LASTS, SO THE ABOVE LIMITATIONS MAY NOT APPLY TO YOU. CAMCO ASSUMES NO LIABILITY OR RESPONSIBILITY FOR BODILY INJURY THAT MAY BE INFLICTED ON THE PURCHASER, OPERATOR, SPECTATOR OR GENERAL PUBLIC WHO IS IN THE GENERAL AREA WHILE THIS EQUIPMENT IS IN USE, FOR THE LOSS OF THE USE OF ANY VEHICLE, LOSS OF TIME, RENTAL OF VEHICLES, LOSS OR DAMAGE TO PERSONAL PROPERTY, EXPENSES SUCH AS GASOLINE, TELEPHONE, LODGING, OR TOWING, OR ANY OTHER INCIDENTAL OR CONSEQUENTIAL DAMAGES INCURRED AS A RESULT OF THE USE OR OWNERSHIP OF ANY PRODUCT. SOME STATES DO NOT ALLOW THE EXCLUSION OF A LIMITATION OF INCIDENTAL OR CONSEQUENTIAL DAMAGES, SO THE EXCLUSION OR LIMITATION SET FORTH MAY NOT APPLY TO YOU. REPLACEMENT OF THE PRODUCT IN THE MANNER PROVIDED ABOVE SHALL CONSTITUTE FULFILLMENT OF ALL LIABILITIES OF CAMCO TO THE PURCHASER WHETHER BASED ON CONTRACT OR OTHERWISE.

CAMCO RESERVES THE RIGHT TO MAKE CHANGES IN DESIGN OR TO MAKE ADDITIONS OR IMPROVEMENTS WITHOUT BEING OBLIGATED TO INSTALL THE SAME UPON PRODUCTS COVERED BY THIS WARRANTY. THIS WARRANTY IS VALID ONLY IN THE UNITED STATES AND CANADA.

CAMCO MFG., INC.

121 Landmark Drive / Greensboro, NC 27409 / USA

1-800-334-2004

www.eaz-lift.com



CD895123 #619 1019665R1