

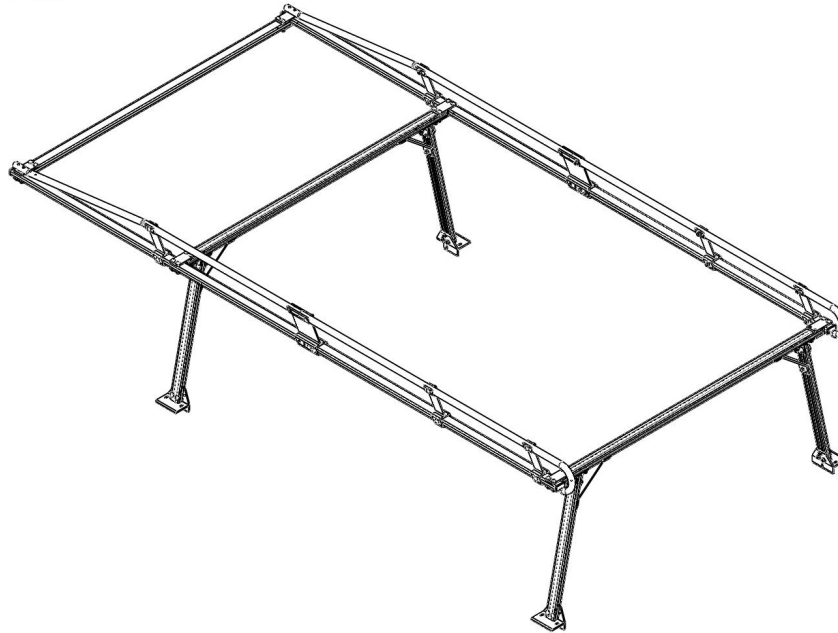

ASSEMBLY INSTRUCTIONS FOR HAULER RACK II - UNIVERSAL TRUCK SERIES RACKS



T11U2863-1 shown above

Package Contents:

HARDWARE KIT

- (4) 3/8"-16 x 3" CARRAIGE BOLTS
- (20) 3/8"-16 x 2" CARRAIGE BOLTS
- (2) 3/8"-16 x 1-3/4" CARRAIGE BOLTS
- (12) 3/8"-16 x 1-1/4" HEX BOLTS
- (12) 3/8"-16 x 1-1/4" HEX LAG BOLTS
- (38) 3/8"-16 NUTS
- (38) 3/8" SPLIT LOCK WASHERS

PARTS

- (1) RAIL DRIVER'S SIDE ASSEMBLY
- (1) RAIL PASSENGER'S ASSEMBLY
- (1) FRONT RECTANGLULAR CROSSBAR
- (1) MIDDLE CROSSBAR ASSEMBLY WITH 'H' & 'T' BRACKETS
- (1) REAR CROSSBAR WITH 'T' BRACKETS
- (2) FRONT LEG ASSEMBLY
- (2) REAR LEG ASSEMBLY
- (4) HD BRACES

Before you begin:

Remove all components from the shipping carton.

The rack should be assembled on a padded surface such as carpet to prevent scratching of aluminum surfaces. Remove bands securing components together.

Read the instructions thoroughly to familiarize yourself with the assembly sequence.

Note that you DO NOT tighten any nuts and bolts until the completed rack is installed on the vehicle unless specified. This allows for minor adjustments to the rack during the installation process.

Gather the following tools used to assemble and install the rack.

- 9/16" Sockets or open end wrenches
- 1/4", 3/8" Drill bits and drill
- Pencil or marker
- Tape measure
- Center punch and hammer (optional)
- Level (optional)
- 2 Clamps (optional)
- Boards (optional)

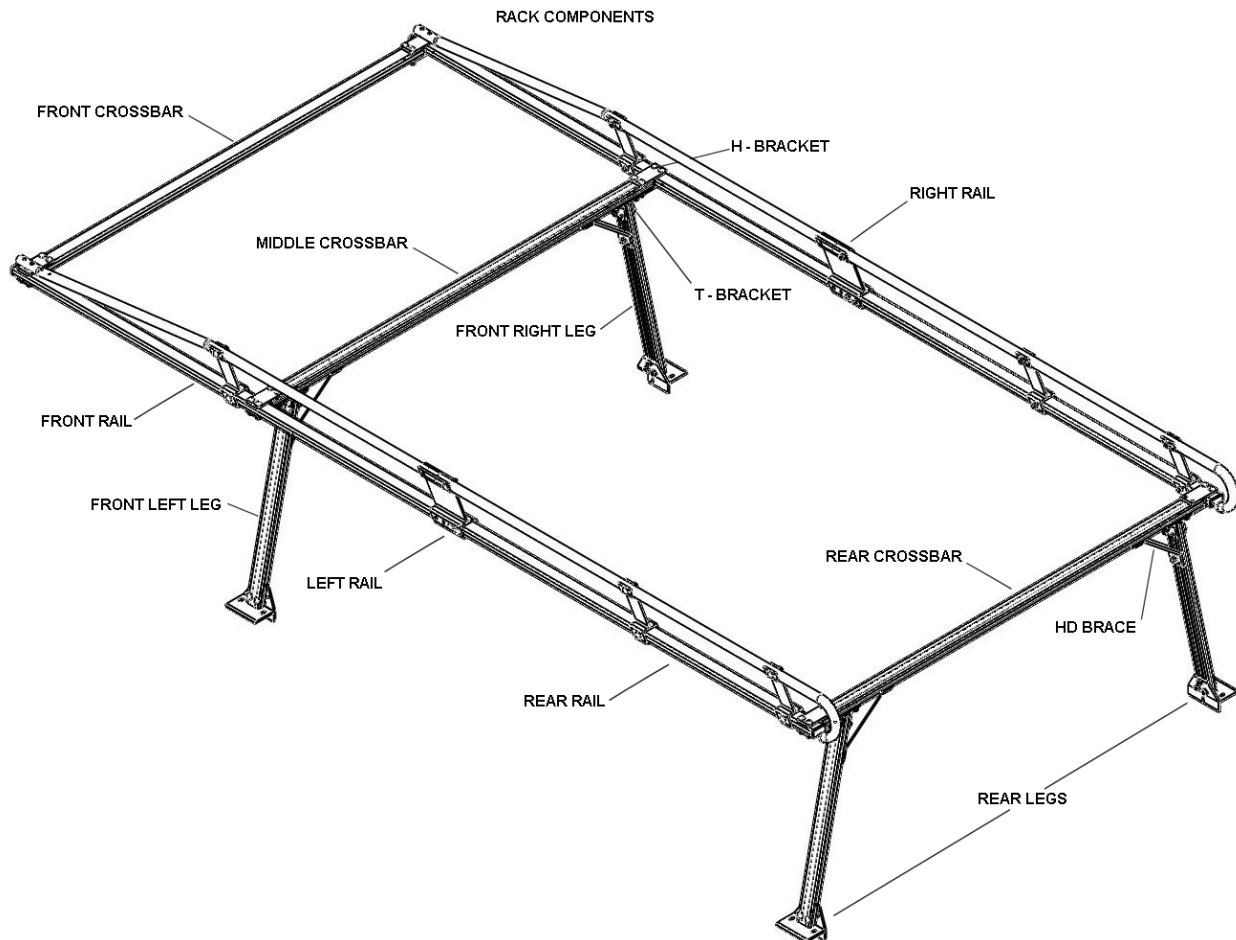

NOTE: If you have a 97-09 Chevrolet or GMC fullsize truck, you will need to change the feet with p/n SPBKIT-1 due to possible stake pockets interference.

1. Connect front and rear sections

Each side rail side contains a front and rear section preassembled for easier assembly. The front and rear sections are banded together.

Remove the banding and separate the front and rear rail sections from packaging.

On a flat surface, place boards under the front and rear rail sections as shown so that the rear 'H' bracket does not touch the ground. This will make aligning the front and rear rail sections faster.

Insert the front rail section into the 5" bracket mounted on the rear rail section and line up the holes.

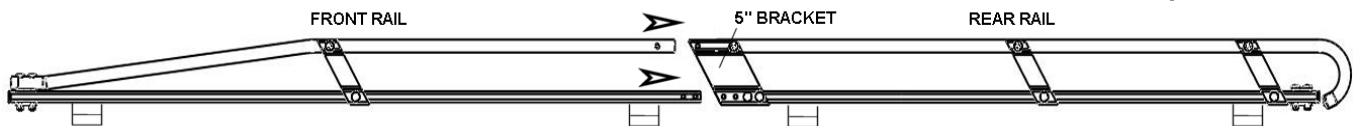

1. (Continued) Connect front and rear sections

Note the orientation of the other carriage bolts on rail assemblies.

For the top round tube, use a 3/8"-16 x 1-3/4" carriage bolt, 3/8" split lock washer and a 3/8"-16 nut, install hardware finger tight. Repeat for other side rail.

For the lower rectangle tube, use (2) 3/8"-16 x 3" carriage bolts, (2) 3/8" split lock washers and (2) 3/8"-16 nuts, install hardware finger tight. Repeat for other side rail.

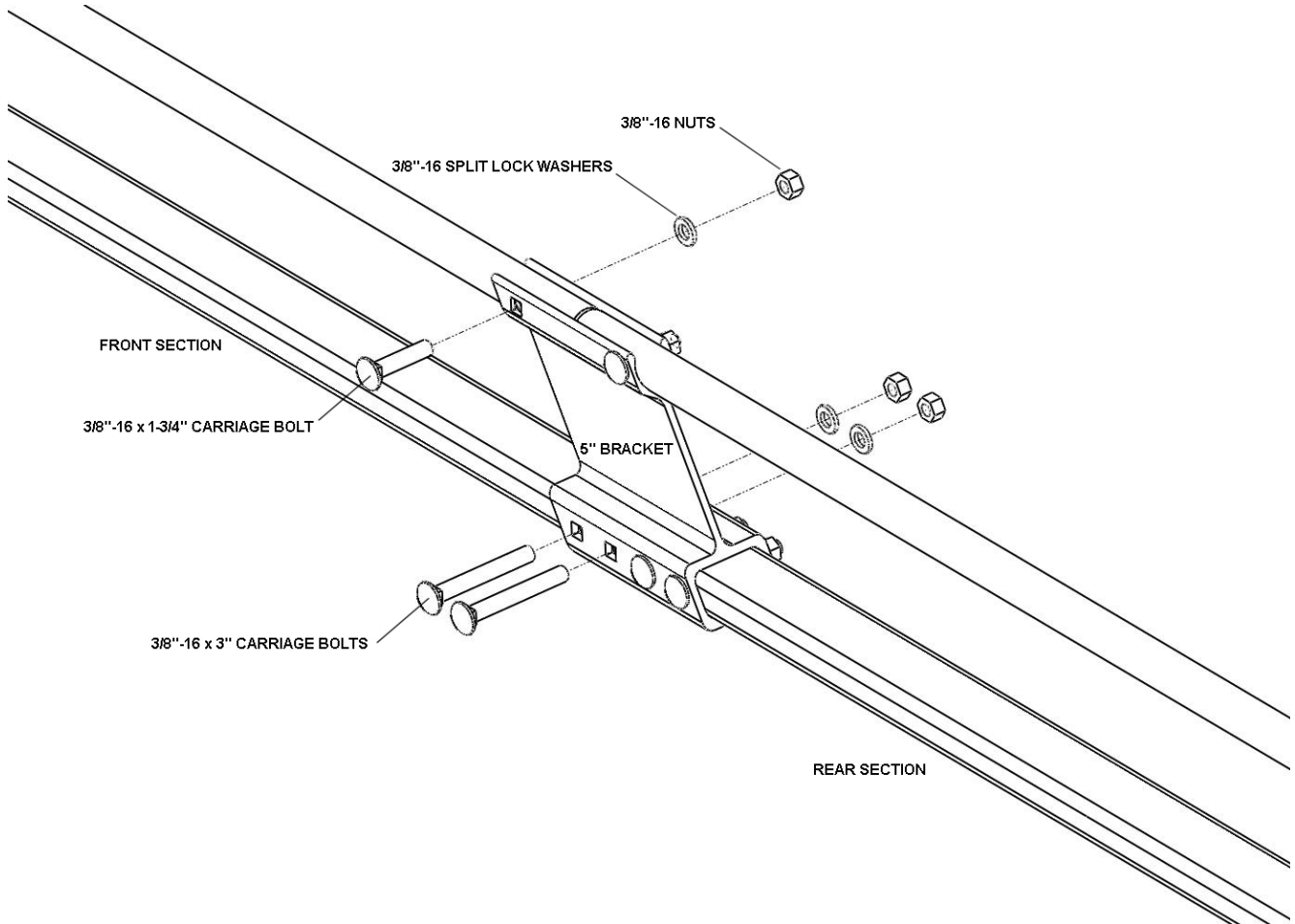

2. Install front Crossbar.

The front crossbar is the smooth rectangle tube with the round bolt holes in each end.

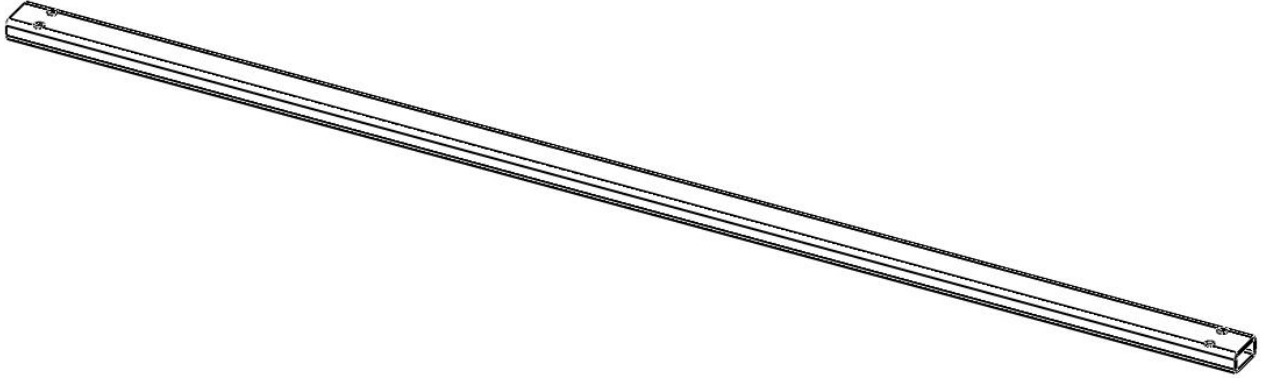

Secure the front cross bar to the 'H' brackets mounted on the side of the front rail sections using (4) 3/8"-16 x 2" carriage bolts, (4) 3/8" split lock washers and (4) 3/8"-16 nuts. Finger tighten only.

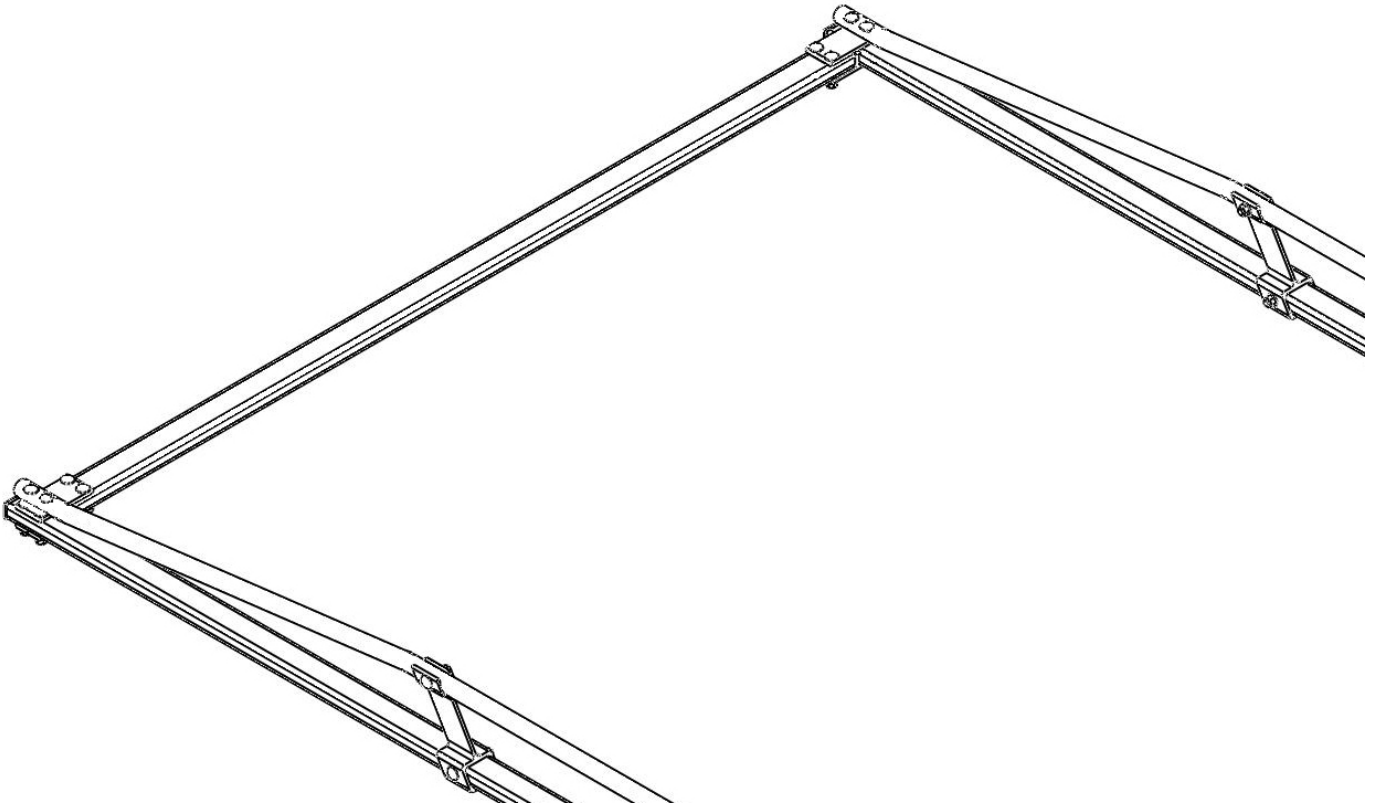

3. Set middle crossbar assembly in place.

The middle crossbar assembly is the ribbed rectangle extrusion with a slotted bottom with 'H' brackets attached to each end and 'T' brackets attached to the slotted bottom.

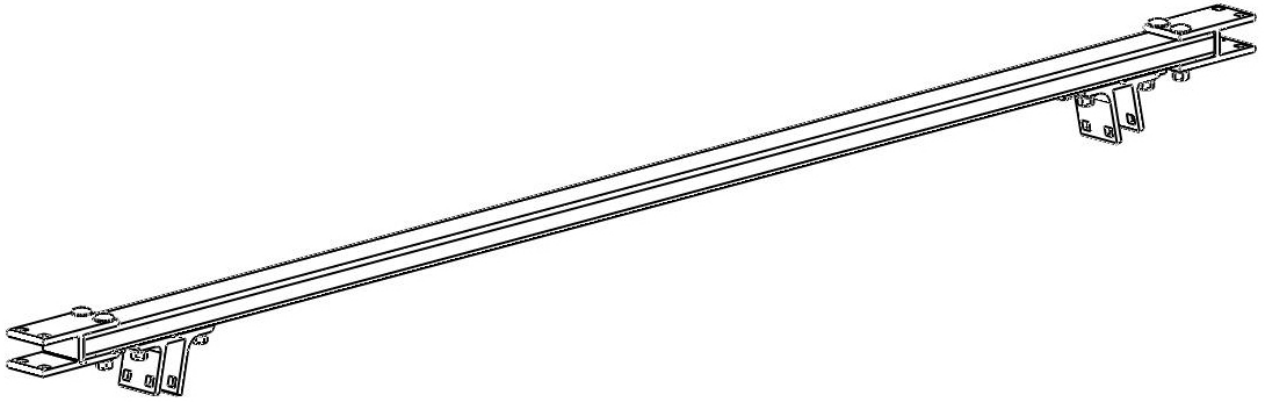

Orientate the crossbar so the ribbed bottom is facing down.

Position the middle crossbar assembly on the front side rails forward of the 5" bracket and about halfway between the 5" bracket and the next support bracket. The middle crossbar assembly will be secured in place after the final adjustments on the vehicle.

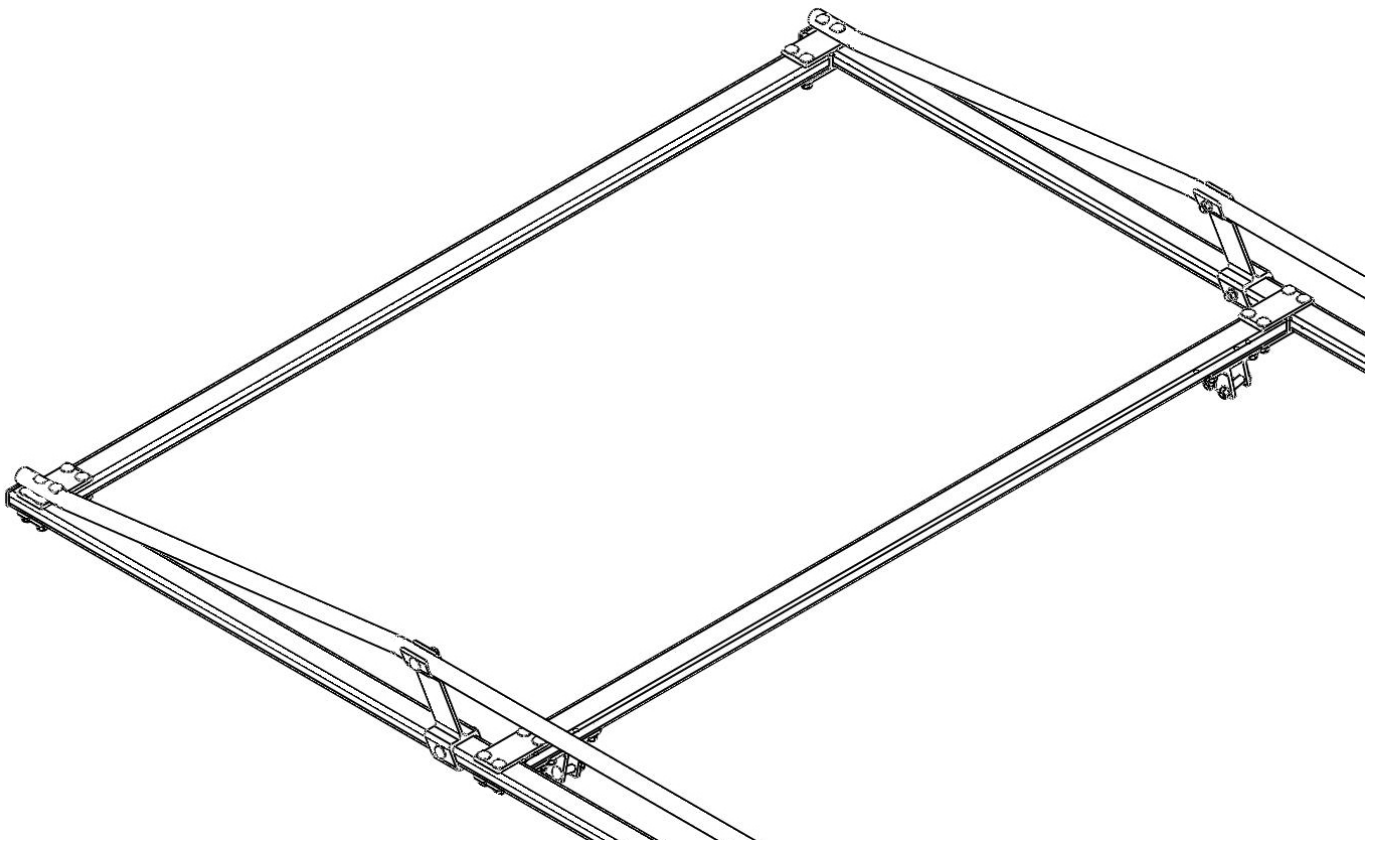

4. Install rear crossbar.

The rear crossbar is the rectangular extrusion with a ribbed bottom and square bolt holes in each end and 'T' brackets attached to the bottom of the crossbar.

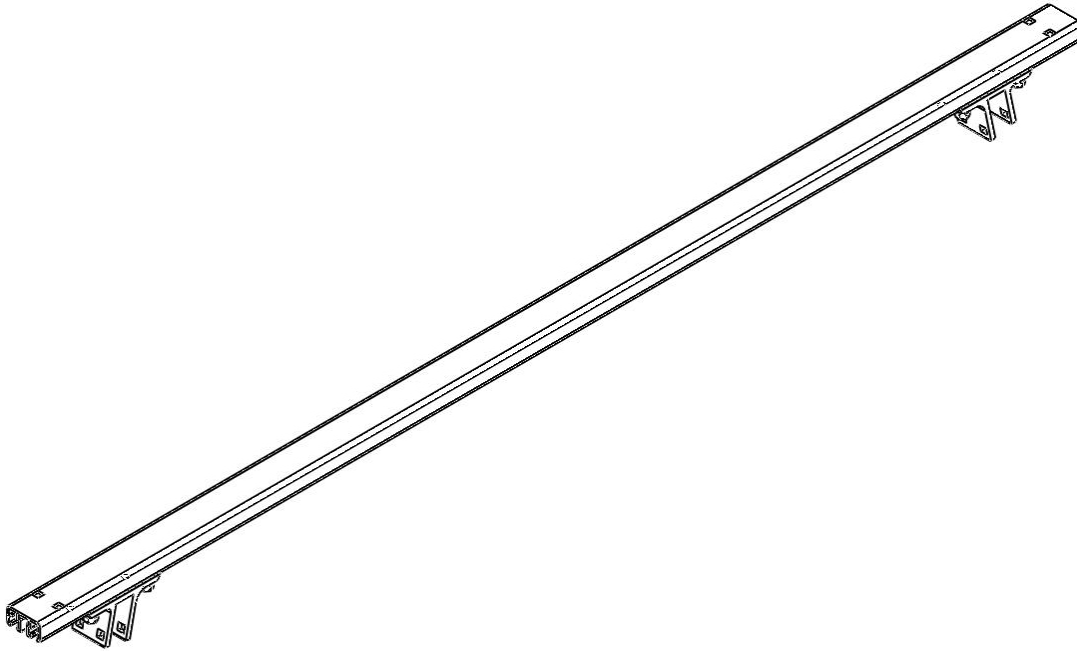

Using (4) 3/8"-16 x 2" carriage bolts, (4) 3/8" split lock washers and (4) 3/8"-16 nuts, secure the rear crossbar to the 'H' brackets mounted at the ends of the rear rails sections. Finger tighten hardware only.

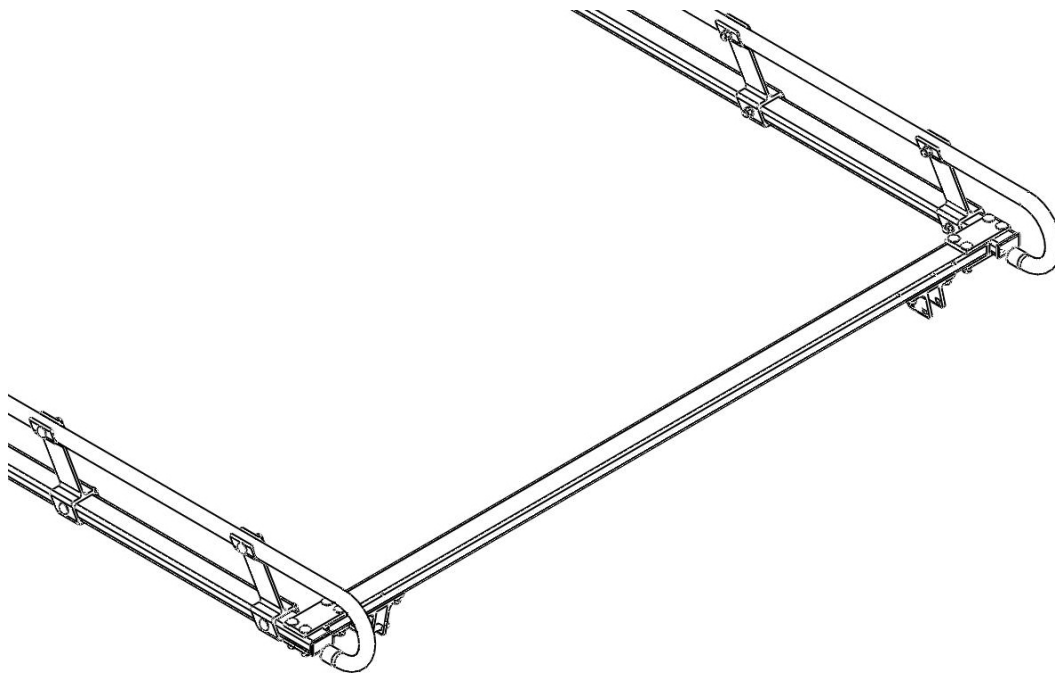

5. Install rear legs

Turn the rack over so the round tubes are on the bottom.

Place the rear legs (legs with un-notched feet) so the ribbed portion faces inwards.

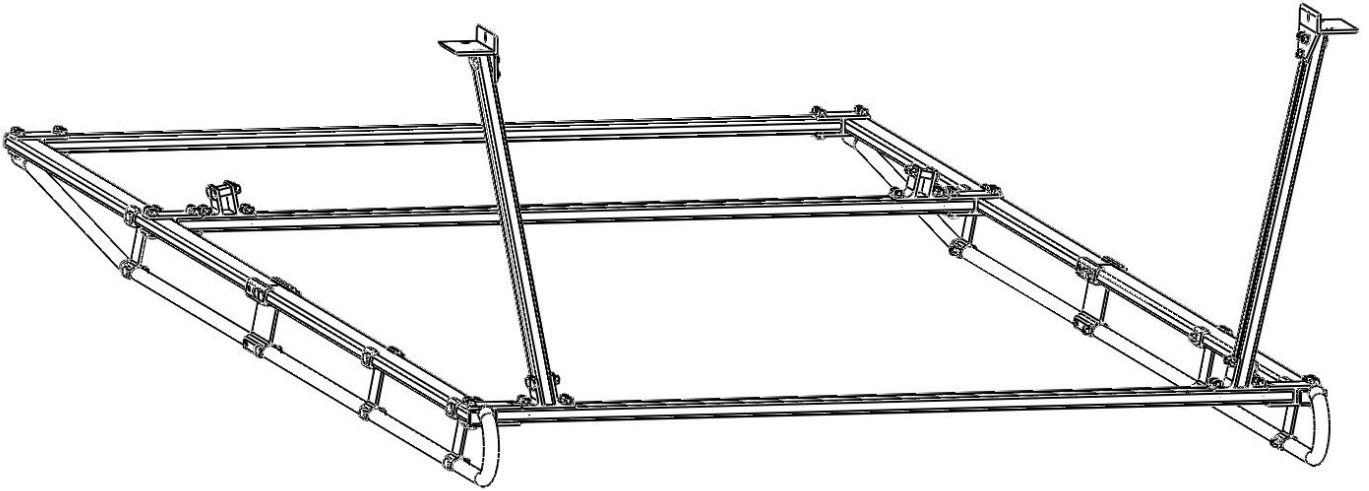

Use (2) 3/8"-16 x 2" carriage bolts, (2) 3/8" split lock washers and (2) 3/8"-16 nuts to secure the leg to the 'T' bracket. Finger tighten hardware. Repeat for other side. Note the orientation of the carriage bolts so they face inwards.

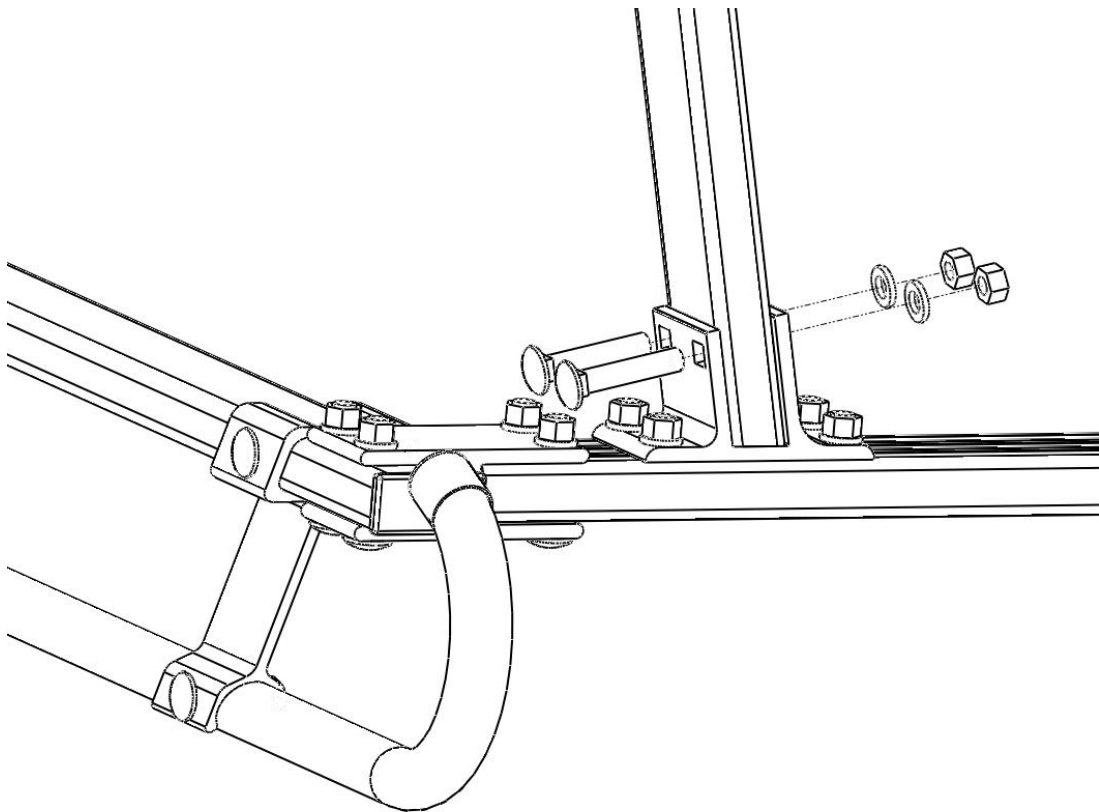

6. Install front legs

The front legs can be identified by the notches in the mounting brackets attached to the bottom of the legs.

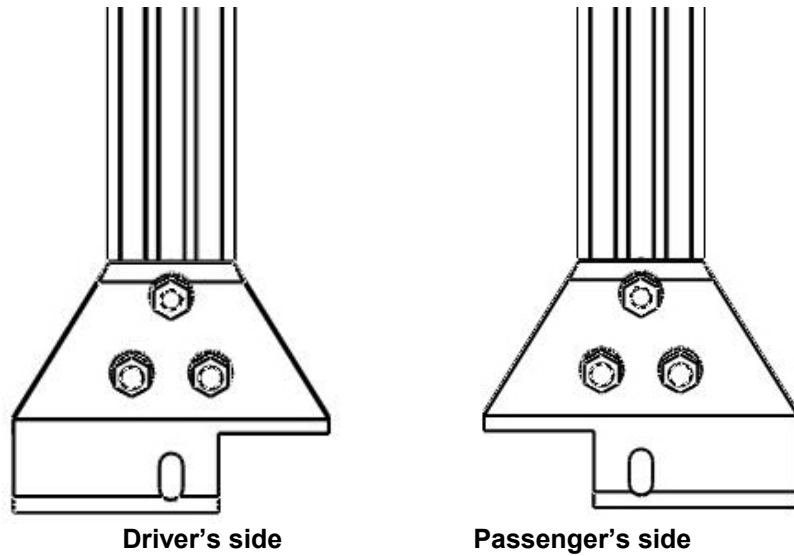

Place the front legs into the 'T' brackets so the notches are facing towards the front of the rack.

Use (2) 3/8"-16 x 2" carriage bolts, (2) 3/8" split lock washers and (2) 3/8"-16 nuts to secure the leg to the 'T' bracket. Finger tighten hardware. Repeat for other side. Note the orientation of the carriage bolts so they face inward.

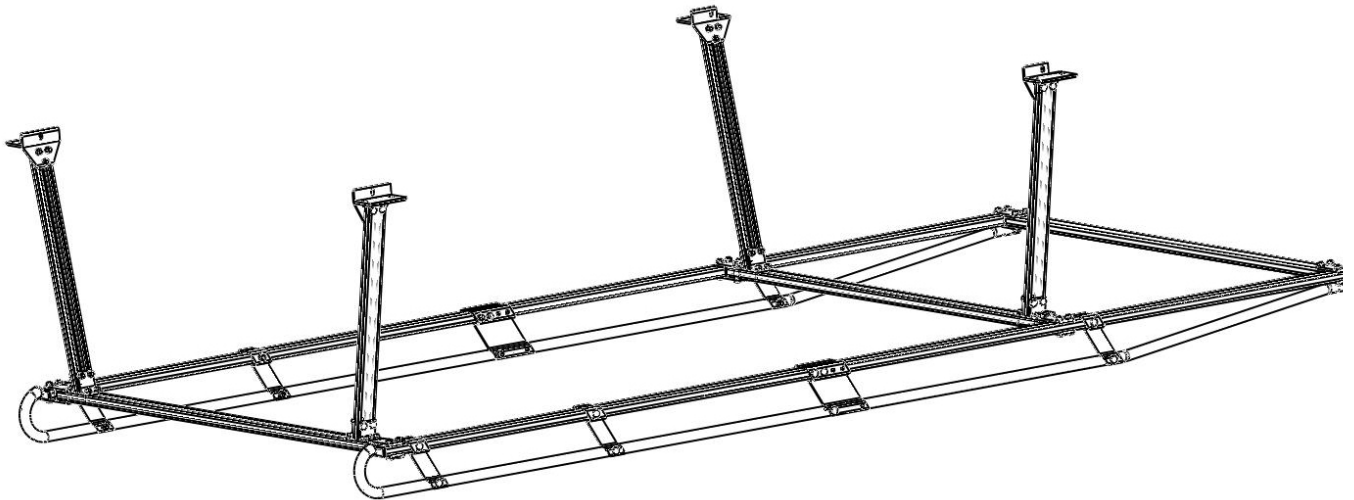

7. Adjust leg span to fit truck bed

Some truck beds vary in width in the front and rear of the bed. Performing the following will help in a quicker setup and centering of the rack on the crossbars without having to readjust the 'T' brackets and HD braces.

Measure the truck bed span (width) at the front and rear of the bed and record in the boxes below.

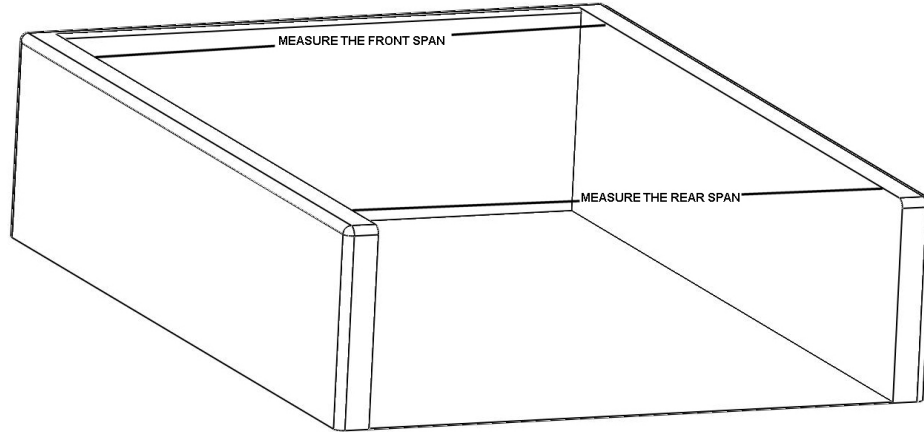

Verify leg length for you specific rack and select which leg height used (length of leg)

24" Leg

26" Leg

28" Leg

4-5/8"

5-1/2"

6-3/8"

The next step will calculate the span between the 'T' brackets. This is the distance from the outside of the 'T' bracket to outside of 'T' bracket on the crossbar as shown below.

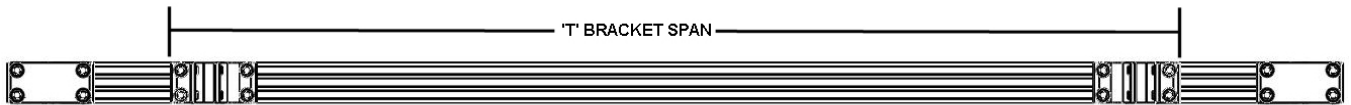

For the middle crossbar which mounts to the front of the truck bed:

Front bed span	Minus	Leg height value from box above	=	Middle 'T' bracket crossbar span
----------------	-------	---------------------------------	---	----------------------------------

For the rear crossbar which mounts to the rear of the truck bed:

Rear bed span	Minus	Leg height value from box above	=	Rear 'T' bracket crossbar span
---------------	-------	---------------------------------	---	--------------------------------

Slide the 'T' brackets with legs apart to the measurement above. Repeat for other crossbar.

Use a tape measure to make sure the 'T' brackets are equally centered on the crossbar by measuring the distance from the outside of the 'T' bracket to the inside edge of the 'H' bracket. Adjust as needed until both sides are equal.

Tighten all the nuts on each of the 'T' brackets.

8. Install HD braces

Remove the 3/8"-16 nuts and 3/8" split lock washers from the floating 3/8" bolts in the legs and crossbar.

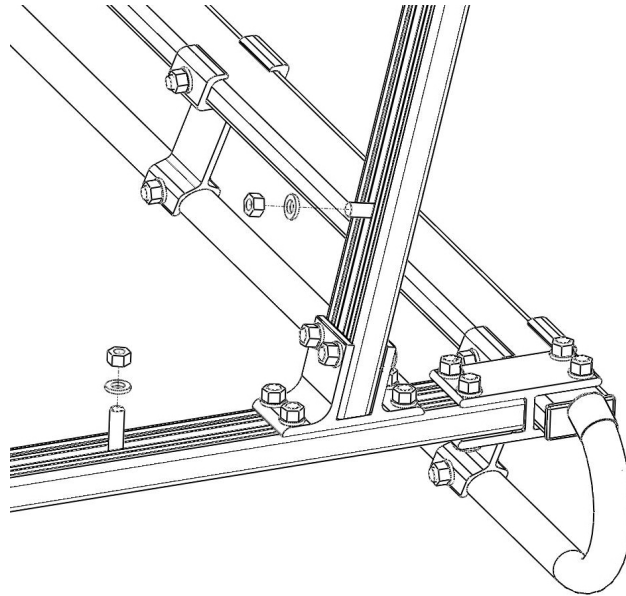

Loosely attach the HD brace to the leg using one of the previously removed 3/8" split lock washers and 3/8"-16 nuts.

Slide the HD brace along the leg to the crossbar.

Align the floating bolt in the crossbar so that the floating bolt goes through the open hole on the HD brace.

Continue to slide HD brace to the crossbar.

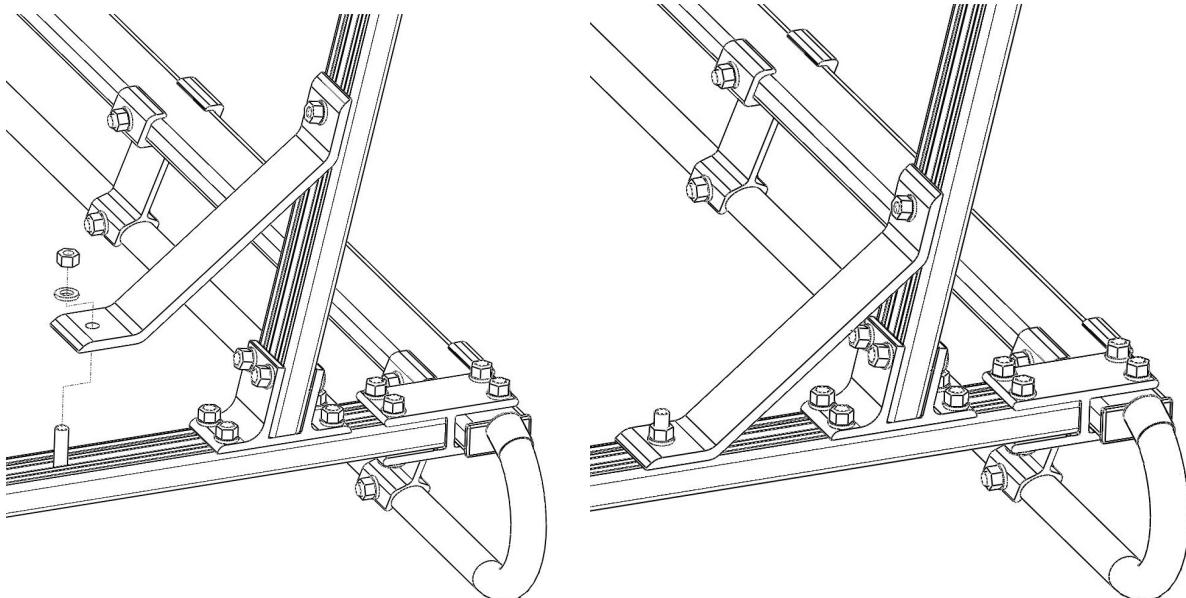

Install 3/8" split lock washer and 3/8-16 nut. Finger tighten the two nuts. Repeat for other corners.

It is normal if the flat ends of the HD braces do not sit flush with the legs and crossbar at this time.

9. Drill and attach middle crossbar / leg assembly

Turn the rack upright and place the rack on the vehicle.

The rear legs should be positioned as far back on the bed edge as possible. Avoid placing attachment bolt holes in brackets over stake pockets. Check to make sure the tailgate can open and close properly.

Temporarily clamp the rear legs in place (optional but suggested).

Slide the front legs with middle crossbar assembly as close to the front edge of the truck bed as possible, again avoiding stake pockets.

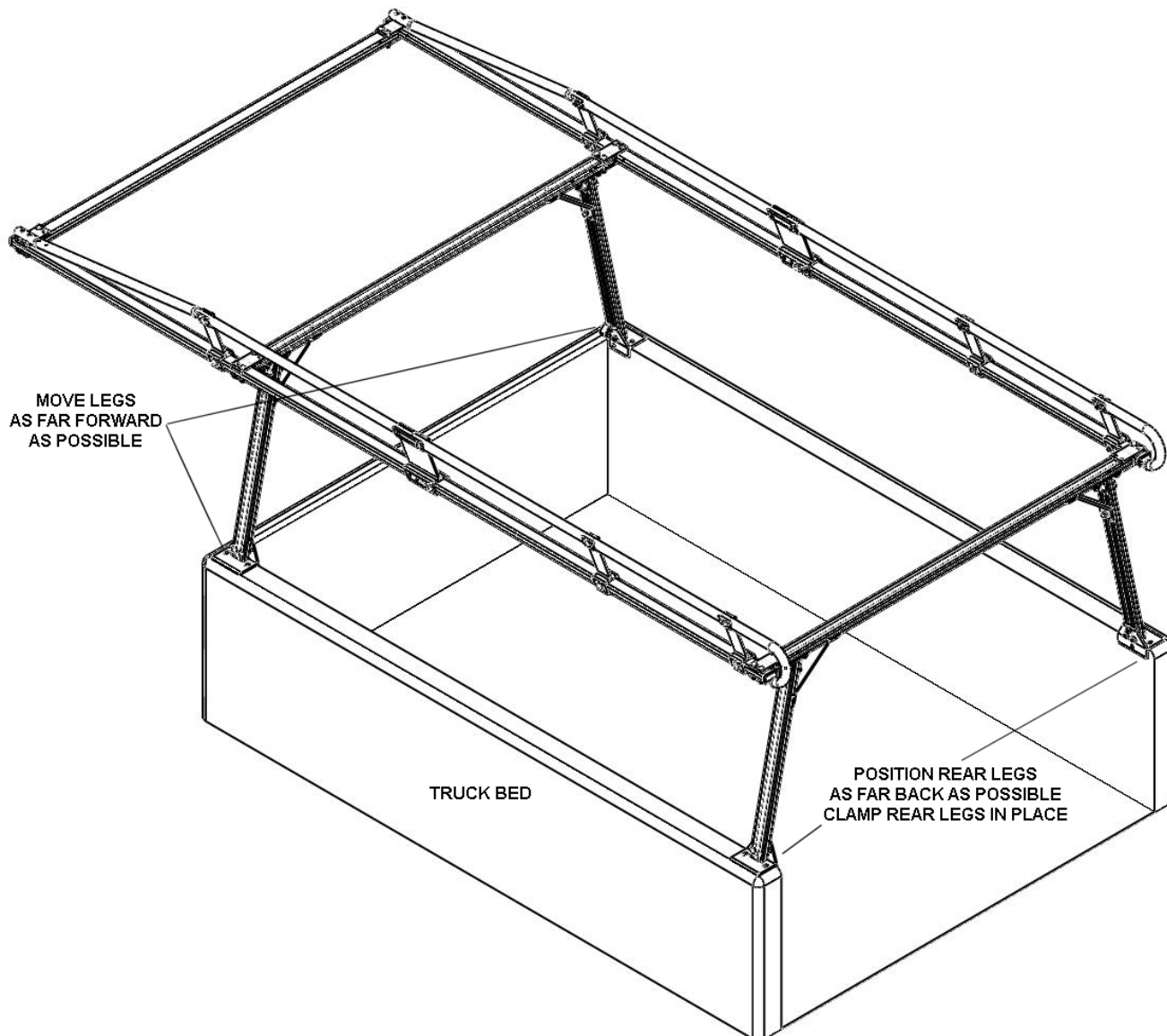

Ensure the entire rack and legs are square to the bed and vehicle. Adjust if needed.

9. (Continued) Drill and attach middle crossbar / leg assembly

Mark the location of the square holes in the ribbed middle crossbar end brackets on the underside of the rectangle side rail tube. For best results use a pencil or marker and trace the outline of the square holes onto the rail. Repeat for other side.

Slide the front leg / middle crossbar assembly backwards enough to gain clearance to drill.

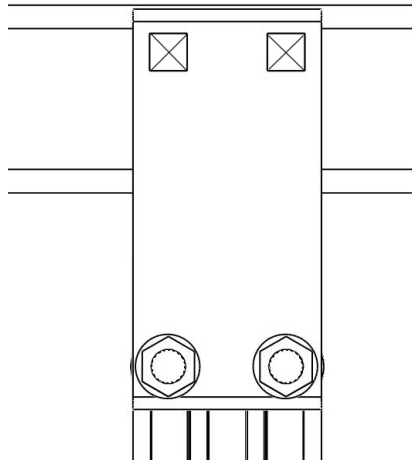

With a pencil or marker, draw lines from corner to corner on square outlined on the rail.

For best results, use a center punch to mark the intersection of the two lines before drilling.

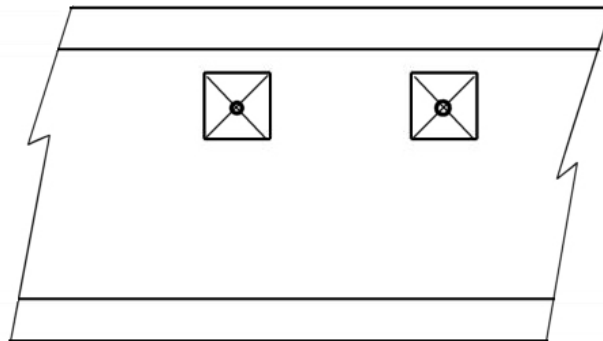

Carefully drill (2) 3/8" holes straight up through the rectangle tube in each side. Note you cannot drill down from the top as the round tube rail is in the way and will prevent drilling a straight hole.

Slide the front leg / middle crossbar assembly forward after drilling both sides.

Use (2) 3/8"-16 x 2" carriage bolts, (2) 3/8" split lock washers and (2) 3/8"-16 nuts to attach the front leg / middle crossbar assembly to the top side railing. Repeat for other side. Finger tighten only.

10. Drill and attach rack brackets to truck bed.

Ensure legs and rack are square and rack is positioned correctly on the truck bed rails. Mark the hole positions on all four legs (3 holes per leg bracket – 2 on top and 1 on the inside)

Examine the truck bed underneath the marked areas to see if access is available to attach nuts to bolts.

If no access is available, drill 1/4" dia holes and use 3/8" hex lag bolts with lock washers.

If access is available, drill 3/8" holes in all locations where marked. Using (12) 3/8-16 x 1-1/4" hex bolts, (12) 3/8" split lock washers and (12) 3/8"-16 nuts, secure the rack to the truck.

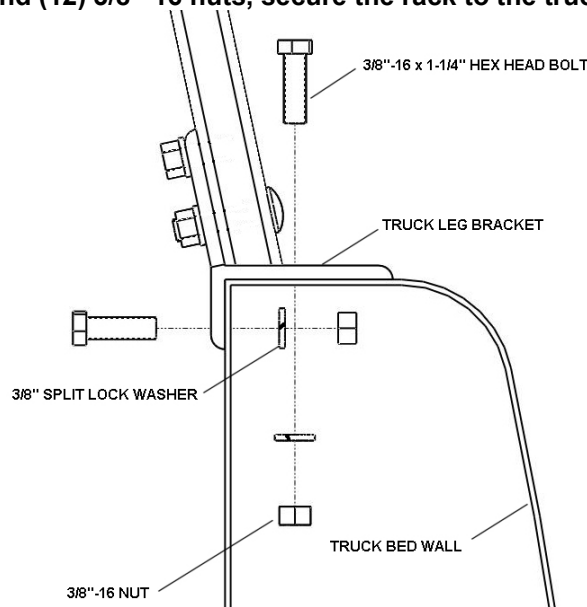

11. Tighten all nuts and bolts

Tighten the rack attachment bolts installed in step 9 first before tightening any other rack bolts. Proceed next to the HD brace nuts. Continue around the rack and tighten all remaining nuts and bolts securely.

Tighten until lock washers are flat but **DO NOT OVERTIGHTEN!**

12. Check all rack hardware to make sure all nuts and bolts have been tightened.

For best use, spread the load out evenly across the crossbars.

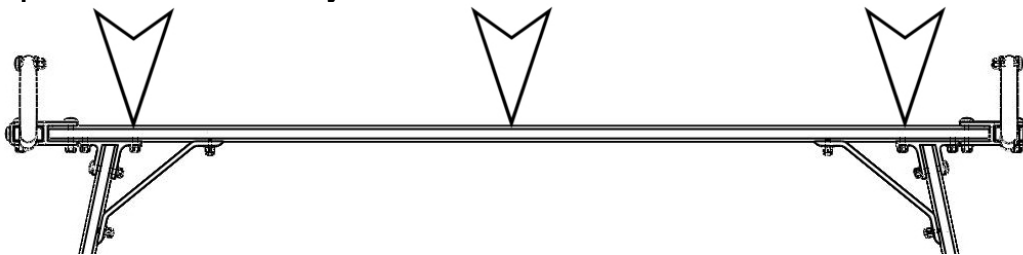

Place the load over the legs between the rear and middle crossbars.

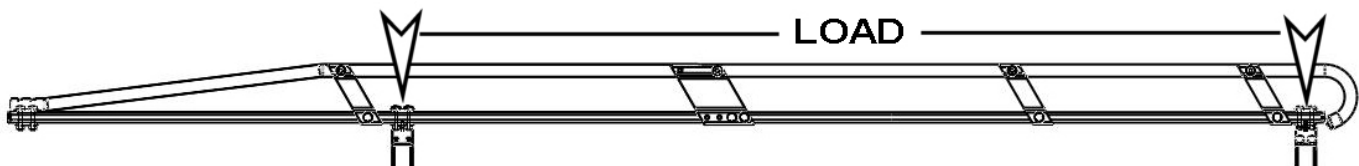

Customer Limited Warranty and Standard Return Policy

Hauler Racks, Inc. offers to preferred customers a special limited warranty. It is our goal to provide effective service for any warranty or standard return. This statement of warranty and return policy is divided into two sections: Warranty Returns of Defective Product and Standard Returns of Unused Product.

Warranty Returns of Defective Product

Hauler Racks, Inc. will repair or replace, at its option and without charge, any properly installed Hauler component that fails due to defect in material or workmanship up to 30 days from the initial registered consumer purchase. All of our aluminum product line is guaranteed not to rust or corrode for 1 year. Proof of Purchase must be provided for warranty to be honored.

Loads should never exceed 1/3 of your vehicle's manufacturer's total load capacity. Loads should never extend more than 1 foot on either end of rack. This warranty is void if any damage to the product is due to misuse, abuse, neglect, accident, improper installation, or any uses contrary to the instructions accompanying the product. The warranty is also void if racks are altered in any manner. The racks have been load tested for the racks capacity to hold loads when not on a vehicle. Hauler Racks, Inc. does not warranty load capacities. As the factory has no way of knowing if the product was properly assembled, installed, used according to instructions, or if loads were secured properly.

This warranty covers the cost of the defective component and not the cost of removal, installation or other incidental charges unless other arrangements have been made with Hauler Racks.

This warranty gives you specific legal rights and you may have other rights which vary from state to state.

All warranty claims must receive a Return Authorization number from Hauler Racks, Inc. BEFORE the product is returned to the Company. Please follow this procedure:

1. Call Hauler at 800-843-5445 to request a Return Authorization number. You will need to provide the following information
 - Specific nature of the defect
 - Product installation date
 - Product part number
 - Original sales invoice number
2. When a replacement or repair strategy is determined, a Return Authorization number will be assigned to the claim.
3. A replacement invoice and shipping document will be generated at Hauler Racks to initiate any replacement product. Replacement product will be sent according to standard shipping cycles.
4. The purchaser is responsible for packing and return shipping of the product. The RETURN AUTHORIZATION NUMBER MUST BE CLEARLY MARKED ON THE OUTSIDE OF THE PACKAGE. Unmarked packages will be refused. Any product damage that occurs during the shipping is not covered under warranty. The purchaser must pursue claims for shipping damage with the shipping center.
5. The purchaser is responsible for payment of both the original product invoice and the replacement invoice according to established credit terms.
6. Upon receipt of the returned product, Hauler Racks will review the claim for warranty conformance. If the claim meets warranty criteria, a credit for the original invoice amount will be posted to the purchaser's account and a credit memo will be mailed. If the claim does not meet warranty criteria, the purchaser will receive a statement detailing reasons for partial credit or denial. At the purchaser's option, denied product may be returned to the purchaser.

Standard Returns of Unused Product

Unused product may be eligible for return to Hauler Racks, Inc. Follow the procedure described in the section on Warranty Returns to receive an Authorization Number.

Returned product which is less than 6 (six) months old is subject to a 20% restocking fee.

Returned product which is more than 6 (six) months old may not be eligible for return or may incur additional restocking charges.