

CONTINUUM™

WITH HENDRICKSON LITEFLEX® TECHNOLOGY

CONTINUUM™ WEIGHT DISTRIBUTION HITCH INSTALLATION MANUAL 16,000 lb. max trailer weight with tongue weight between 600lbs. & 1,600 lbs.

WDHK4500

WDHH4500

Head unit with 2" Shank

WDHL4510

Load bars and hydraulic unit
with NO cylinder extension

WDHK4501

WDHH4500

Head unit with 2" Shank

WDHL4511

Load bars and hydraulic unit
WITH cylinder extension

WDHK4502

WDHH4502

Head unit with 2-1/2" Shank

WDHL4510

Load bars and hydraulic unit
with NO cylinder extension

WDHK4503

WDHH4502

Head unit with 2-1/2" Shank

WDHL4511

Load bars and hydraulic unit
WITH cylinder extension



CALL OR E-MAIL FOR INSTALLATION SUPPORT
PHONE: 800-248-6564
hitches@turnoverball.com

Continuum Hitch Components

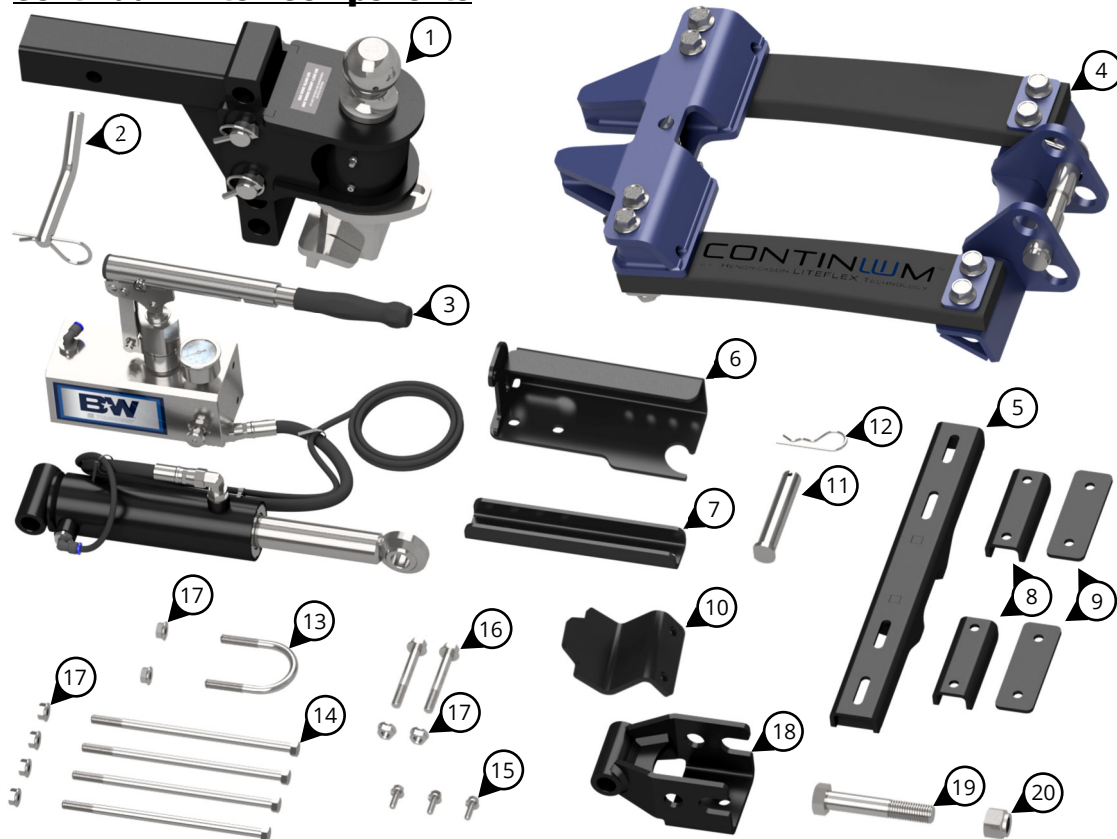

BOX: WDHH4500 & WDHH4502		
#	DESCRIPTION	QTY
1	Head Unit	1
2	3/4" Receiver Pin w/ Cotter	1

BOX: WDHL4510* & WDHL4511		
#	DESCRIPTION	QTY
3	Hydraulic Pump & Cylinder	1
4	Load Bar Assembly	1
5	Top Cylinder Mount	1
6	Pump Mount Bracket	1
7	Pump Mount Inside Clamp	1
8	Frame Clamp	2
9	Top Mount Washer Plate	2
10	Fork Holder Bracket	1
11	Top Cylinder Mount Pin	1
12	Cotter Pin	1

BOLT BAG: 4210-200		
#	DESCRIPTION	QTY
13	2" x 3" x 3/8" U-Bolt	1
14	3/8" x 8" Cap Screw	4
15	3/8" x 3/4" Flange Head Bolt	3
16	3/8" x 3" Flange Head Bolt	2
17	3/8" Flange Nut	8

Extension kit (*not present in WDHL4510 box)		
#	DESCRIPTION	QTY
18	Hydraulic Cylinder Extension	1
19	3/4" x 4-1/4" Cap Screw	1
20	3/4" Lock Nut	1

IMPORTANT SAFETY NOTICE FOR HITCH INSTALLERS AND CUSTOMERS.

Read all installation and operating instructions along with all labels before installing or using this product. Do not perform any installation or towing procedures without fully understanding the correct tools and actions for all steps. Call B&W Trailer Hitches Customer Service Department for support, if needed.

⚠️ WARNING

Failure to comply with the safety information in these instructions could result in serious injury or death.

- ⚠️ Do not modify this product in any manner. Doing so could alter its integrity and lead to a loss of attachment between the trailer and the tow vehicle.
- ⚠️ Adding hitch components to the chassis of any vehicle or trailer can be hazardous. There is potential for unexpected combustion of fuel, electric shock, burns, shifting or falling of unstable vehicle, damage to vehicle, injury from tool usage and many other hazards. This installation must be completed by someone who is aware of the hazards involved. This person must be knowledgeable of proper safety procedures for a vehicle and trailer modification of this nature, and for usage of the equipment required to perform the installation.
- ⚠️ Without proper knowledge, towing can be a dangerous activity. Understand all the risks involved with towing before proceeding. For information on towing safety, see **"The Trailer Handbook: A Guide to Understanding Trailer and Towing Safety"** from the National Association of Trailer Manufacturers, www.NATM.com and your trailer and tow vehicle manufacturer's owner's manual.
- ⚠️ Do not exceed tow or tongue rating of coupler, tow or tongue rating of hitch, or tow or weight ratings of tow vehicle or trailer. See vehicle and trailer manufacturer information for ratings. Exceeding these ratings may cause damage to towing components or loss of attachment between the trailer and vehicle.
- ⚠️ A visual inspection of the towing components should be performed before each use. Regularly check that all connections are secure, including those that secure the hitch to the vehicle. Check for cracks or damage to the hitch, tow vehicle receiver, trailer coupler and frame. Do not use the hitch if cracks or damage outside of normal wear is found. Using a hitch that has unsecure connections and/or cracks or damage could result in damage to the tow vehicle, trailer, towing components and loss of attachment between the tow vehicle and trailer.
- ⚠️ Follow all manufacturer instructions and warnings for tow vehicle and trailer. The Continuum weight distribution hitch is designed to work with vehicles and trailers designed to use weight distribution hitches. Do not use the Continuum hitch with any vehicle or trailer that is not compatible for use with a weight distribution hitch.
- ⚠️ While installation is being performed, check for signs of damage or excessive corrosion. Do not install hitch components over vehicle or trailer parts that are broken or have compromised structural integrity.
- ⚠️ Tire condition can influence trailer sway. Never tow with tires that are under inflated, over loaded, or damaged. These conditions will greatly lower the speed at which the trailer will remain stable and may lead to loss of control. Check tire condition before each tow.

CHECK TRAILER COMPATIBILITY

- Coupler ball size.** The Continuum hitch is configured for trailers with 2-5/16" ball couplers. 2" ball replacements are available for purchase from B&W. Changing the ball requires specialized tools, for this reason B&W recommends having a dealership replace the ball. Detailed information on ball replacement is shown on page 10.
- Coupler style.** The coupler of the trailer will determine if you need an extension on your cylinder. There are two different weight distribution hitch kits available depending on the distance between the top of the trailer frame rails and the top of coupler.
 - B&W Kit# [WDHL4510](#) is necessary if the top of the coupler is above the trailer frame or *less than 2.5"* below the top of the trailer frame, **see top half of Figure A1.**
 - B&W Kit# [WDHL4511](#) is necessary if the top of the coupler is *more than 2.5"* below than the top of the trailer frame, **see bottom half of Figure A1.**
- Tow configuration.** The Continuum hitch fits a majority of tow vehicle and trailer configurations. Review each point below to confirm your configuration is compatible.
 - The Continuum hitch is rated for trailers that weigh a maximum of 16,000 lbs. It is capable of supporting tongue weights of 600 lbs. to 1,600 lbs.
 - Only trailers with an A-frame coupler design can be used with the hitch.
 - The A-frame rails must be approximately 2" wide and 5" to 6" tall. Frame rails which are shorter (4" minimum) or taller (7" maximum) are supported, but require alternate bolts. This alternate hardware is available upon request from B&W.
 - The area behind the coupler and between the frame rails must be open with at least 2" of open space in front of the next object, such as the propane tank tray. The mounting location behind the coupler requires the distance between the frame rails to be between 6" and 9", **see Figure A2.**
 - A clear span of frame rail is needed on the driver side of the trailer to mount the hydraulic pump, **see Figure A3.**
 - If the foot pad of the trailer jack is wider than 6-1/2" it will need to be removed during installation.
 - The tow vehicle must have a receiver with an opening no smaller than 2". Reducers may be used if the receiver is larger than 2".

NOTE: On some vehicles the use of a reducer sleeve reduces the tow ratings of the vehicle, refer to vehicle user manual.

- The height of the trailer coupler and the tow vehicle receiver must be within the adjustment range of the hitch. Use **Figure A4** and the formula below to determine if the height of the trailer and tow vehicle will allow the hitch to couple. The top of **Figure A4** shows the adjustment range of the hitch.

Measurement A: Level the trailer on flat ground, then measure the distance from the top of the coupler to the ground.

Measurement B: Measure the distance from top inside edge of to vehicle receiver to ground.

Use formula $A + 2 - B$.

If answer is between **-1-1/8" and 9-3/8"** then the tow vehicle and trailer are compatible.

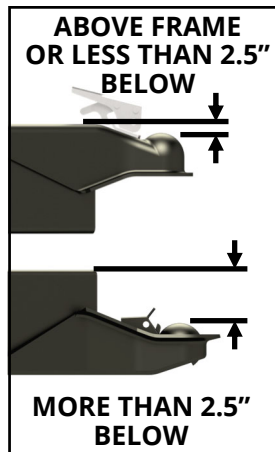

FIGURE A1:

Distance between top of frame and top of coupler ball.

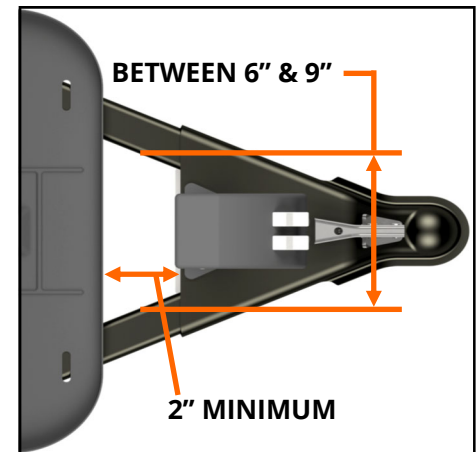

FIGURE A2: View above trailer A-frame and coupler.

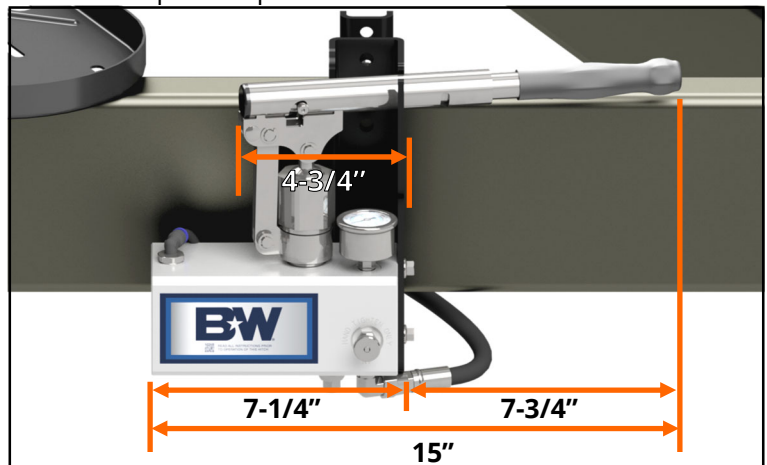

FIGURE A3: View of driver side frame rail.

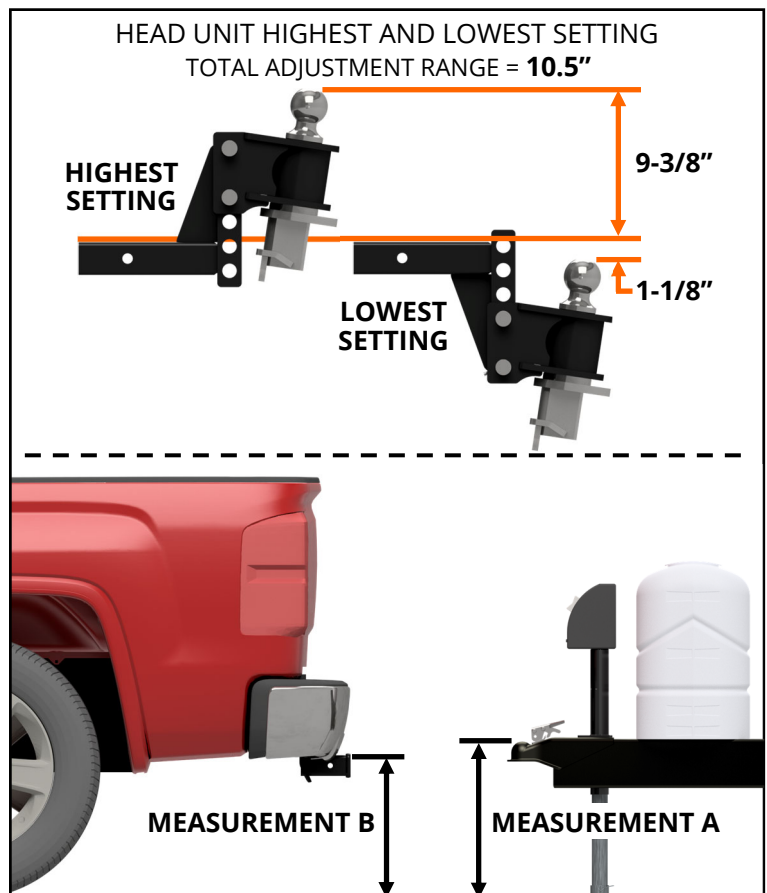

FIGURE A4: View of trailer and tow vehicle.

PREPARE FOR INSTALLATION

TOOLS REQUIRED

- Ratchet with 9/16" socket.
- If installing WDHL4511 a 1-1/8" socket and box end wrench
- Torque wrench
- Marker
- Tape measure
- Eye protection
- Vent hose cutting tool

1. **Prepare tow vehicle and trailer.** Both the trailer and the tow vehicle must be set up properly before beginning installation. Complete each point below.
 - The trailer and the tow vehicle must both be on a flat, level area.
 - Chock trailer tires when working around the trailer.
 - Level the trailer. Measure the distance between the trailer frame and the ground at the front and the rear of the trailer. Adjust trailer until these measurements are equal.
 - The truck and trailer must be fully loaded during hitch installation and setup, just as they would be when towing.
 - Review factors that can adversely affect sway under the FAQ section on page 10.

2. **Prepare hitch components.** Remove the hitch components from each of the boxes. Compare the parts to the second page to become familiar with them and verify they are all present and undamaged by shipping.

NOTE: It may be necessary to relocate the trailer's break-away cable, propane lines, and the trailer's wiring harness for a proper and safe installation. During installation carefully move or re-route any wires, cables, or hoses that may become damaged or pinched by the addition of the hitch.

INSTALL HEAD UNIT

1. **Configure and install head unit.** Determine in which position the head unit should be pinned. Measure the distance from the ground to the top of the trailer ball coupler, **see Figure B1**. Place the head unit into the receiver of the tow vehicle. Measure how high the ball is above the ground, **see Figure B2**. The ball should be set **1-2" higher** than the coupler measurement. Remove the head unit and adjust the pins to set the ball height correctly. The holes in the pin blocks are 1-1/2" apart. If required, the pin block can be turned over.

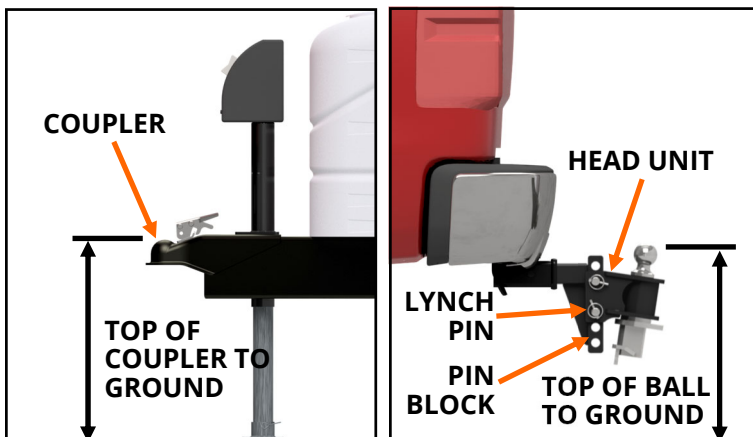

FIGURE B1: Side view of trailer. FIGURE B2: Side view of tow vehicle.

2. **Secure head unit.** Using the hole in the receiver, pin the head unit to the tow vehicle and secure with a cotter pin. Secure the pins in the pin block with lynch pins.

NOTE: The lynch pin spring must close on the same side as the bump on the top of the pin, **see Figure B3**.



FIGURE B3: Lynch pin

INSTALL HYDRAULIC PUMP

1. **Prepare trailer frame.** Prepare the trailer A-frame for installation of the hydraulic pump unit.
 - If present, mark the front and back edges of the propane tank cover, **as shown in Figure C1**. Then remove the propane tank cover.
 - If present, remove the propane tanks and set them aside to allow clearance for installing the hitch.
 - If present you may need to remove the propane tank tray. In some cases, it may not need to be removed if there is enough space between the tray and the rear edge of the coupler (2.5" or more). Before the tray is removed, mark the edges of the tray on the trailer frame so it can be reinstalled in the same location, **as shown in Figure C2**. These marks will be referenced when mounting the pump.

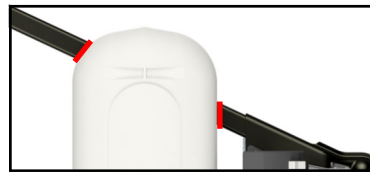

FIGURE C1: Top of A-frame with propane tank cover.

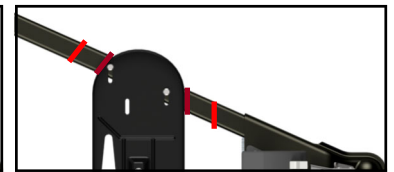

FIGURE C2: Top of A-frame with propane tank tray.

2. **Attach the pump mount bracket.** Locate the pump mount bracket, inside clamp, two 3/8" x 3" bolts, and two 3/8" flange nuts. Depending on the height of your trailer frame, identify which hole to use for mounting the pump mount brackets, **see Figure C3**. Place the pump mount bracket and inside bracket next to the driver side frame and attach using the 3/8" bolts and nuts, **as shown in Figure C4**. Leave the nuts loose.

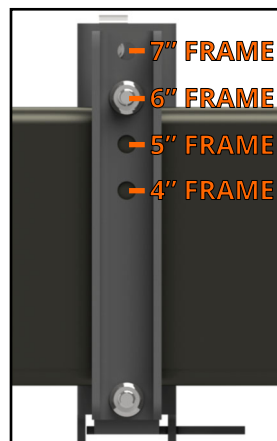

FIGURE C3: View of the inside clamp.

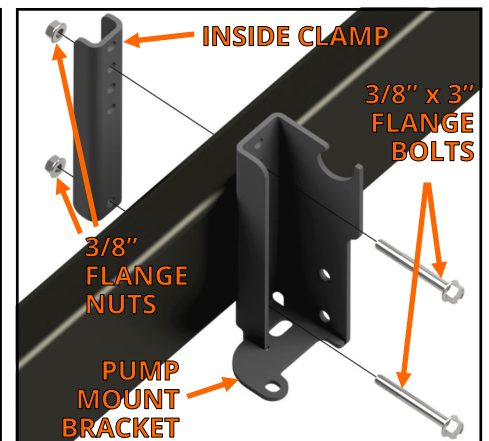

FIGURE C4: View of driver side frame rail.

INSTALL HYDRAULIC PUMP Continued

3. **Position the pump mount bracket.** Using **Figure A3 on page 3**, locate a clear span of the driver side frame to secure the hydraulic pump. If the trailer had a propane tank cover, the installation area should be roughly 4" behind the mark made on the frame, **as shown in Figure C5**. Relocate any obstacles or cables that may be in the area needed for pump installation. When the best location for the hydraulic pump unit has been determined, adjust the pump mount bracket so it is level with the frame. Tighten the two 3/8" nuts holding the pump mount inside clamp by alternating between each nut so that when tight, the inside clamp and pump mount bracket are flat against the frame rails, **see Figures C6 and C7**. Torque the 3/8" nuts to 40 ft.-lbs.

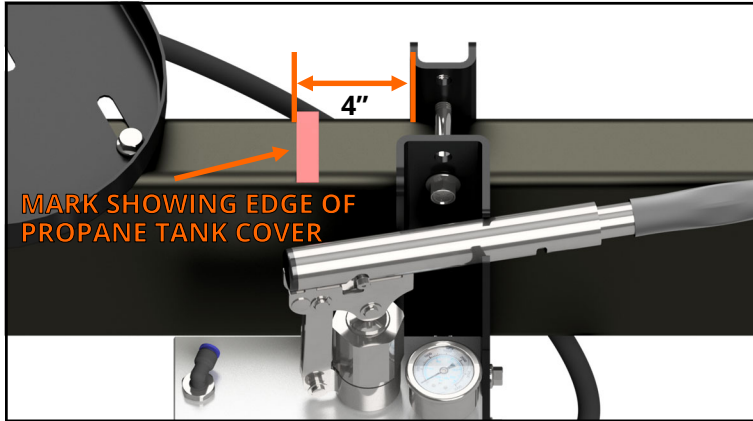

FIGURE C5: View looking at the driver side frame rail.



FIGURE D6: View showing a correctly tightened inside clamp.



FIGURE D7: View showing an incorrectly tightened inside clamp.

4. **Mount the hydraulic pump.** Retrieve the hydraulic pump and cylinder. Carefully lay the hydraulic cylinder below the A-frame temporarily. Retrieve the three 3/8" x 3/4" flange bolts. Attach the hydraulic pump to the pump mount bracket using the bolts, **as shown in Figure C8**. Torque the 3/8" bolts to 40 ft.-lbs.

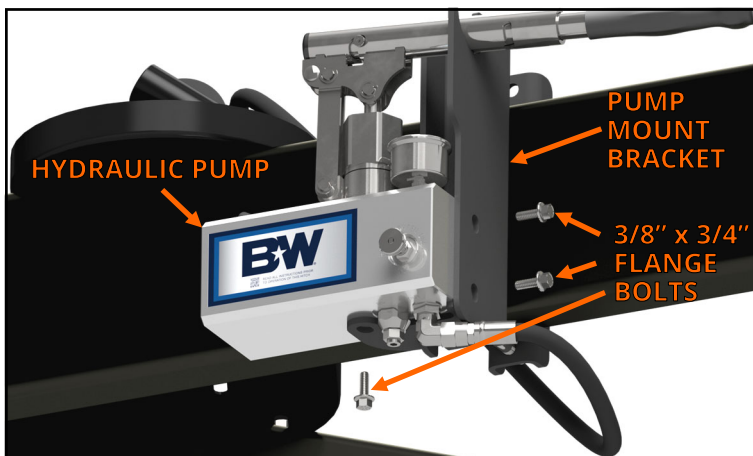

FIGURE C8: View looking at the driver side frame rail.

WARNING: Do not tamper or attempt to adjust the pressure relief valve on the bottom of the hydraulic pump. It is set at the factory to a safe level. Adjusting the pressure release valve could result in serious injury or death.

NOTE: If your handle interferes with parts of the trailer after installation is complete, the pump will have to be moved. Remove the pump and loosen the pump mount bracket bolts to adjust the pump location. Follow Steps 3-4 to reinstall the pump at a new location.

INSTALL HYDRAULIC CYLINDER

1. **Install hydraulic cylinder extension.** If installing kit# WDHL4510 skip to Step 2. If installing kit# WDHL4511 bolt the hydraulic cylinder extension to cross tube of the hydraulic cylinder using a 3/4" x 4-1/4" cap screw and 3/4" lock nut, **see Figure D1**. Torque the nut to 150 ft.-lbs.

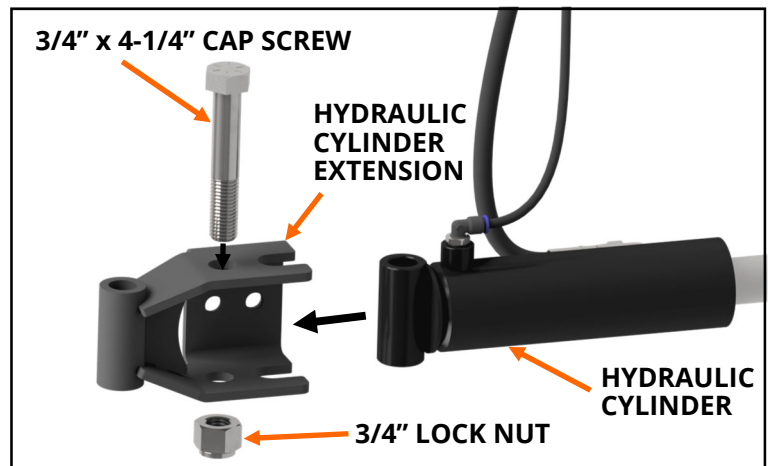

FIGURE D1: View of hydraulic cylinder.

2. **Position the hydraulic cylinder.** Carefully lift the hydraulic cylinder. Move the cylinder up under the trailer A-frame so the hydraulic hose passes under the driver side frame rail. With the cross tube end of the cylinder up, pass the cylinder between the two rails of the A-frame. Pin the cylinder to the top cylinder mount and secure with the provided cotter pin, **as shown in Figures D2 and D3**. Rest the top cylinder mount on the frame.

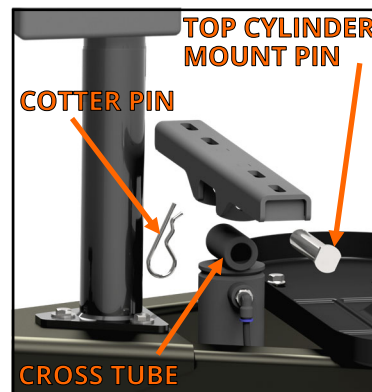

FIGURE D2: View of the cylinder above the A-frame.



FIGURE D3: View of the cylinder and extension above the A-frame.

INSTALL HYDRAULIC CYLINDER *Continued*

3. **Assemble the hydraulic cylinder mount.** Retrieve the top mount washer plates, frame clamps, 3/8" x 8" cap screws, and four 3/8" flange nuts. Place the top mount washer plates over the top cylinder mount slots. Place a 3/8" x 8" cap screw in each of the holes in the washer plates. Two of the screws will be on the inside of the A-frame and two will be on the outside, **see Figure D4**. Depending on the height of the frame rails, place the frame clamps over the 3/8" cap screws, **see Figure D5**. Use the 3/8" flange nuts to attach the frame clamps, do not fully tighten nuts at this time.

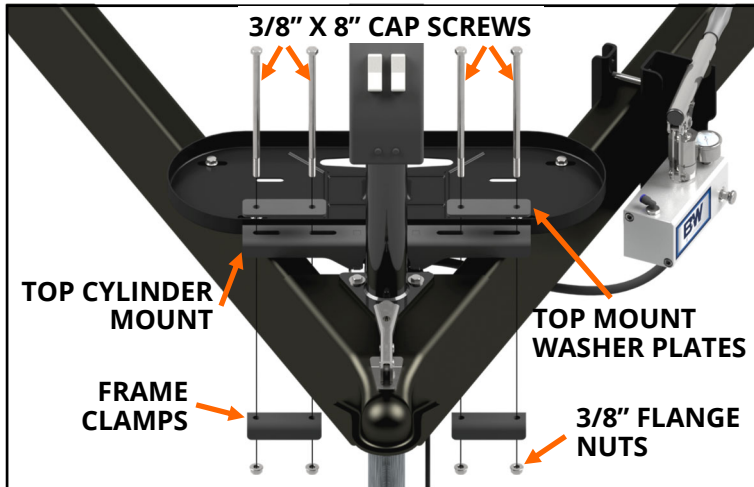

FIGURE D4: View looking at the front of the trailer.



FIGURE D5: View of the frame clamps below the frame.

4. **Reinstall propane tank tray.** If the propane tank tray was removed for installation, use the marks made on the frame to reinstall the tray.
5. **Secure the hydraulic cylinder.** Push the top cylinder mount as far back as possible. Use a tape measure to check that the top cylinder mount is square with the trailer and centered left to right. Tighten the four 3/8" nuts holding the frame clamps by alternating between each nut so that when tight, the frame clamps are flat against the bottom of the frame rails, **see Figures D6 and D7**. Torque the 3/8" nuts to 40 ft.-lbs.

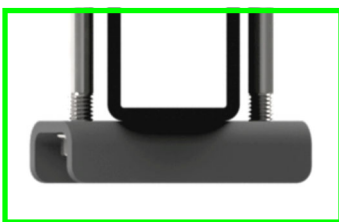

FIGURE D6: View showing a correctly tightened frame clamp.



FIGURE D7: View showing an incorrectly tightened frame clamp.

COMPLETE HYDRAULIC INSTALLATION

1. **Reinstall propane tanks and cover.** If your trailer had propane tanks and cover reinstall them at this time.
2. **Retract the cylinder.** If the cylinder is not completely retracted into the cylinder barrel, retract the cylinder by closing the needle valve and pumping the handle. Pump just enough to retract the cylinder. Don't apply any pressure to the gauge.
3. **Complete vent hose installation.** Pull the vent hose up between the frame and the hydraulic pump unit. Push in on the blue fitting to remove the plug from the air hose fitting on the top of the hydraulic pump. Cut the vent hose to length and insert the cut end into the air fitting and press in firmly, **see Figure E2**.

NOTE: It is normal for a small amount of pressure to be released when the plug is pulled out of the air hose fitting.

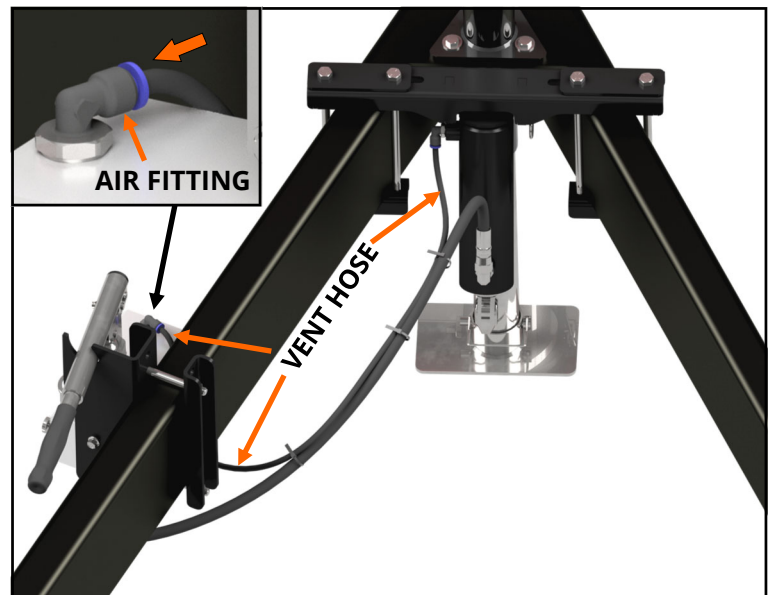

FIGURE E2: View looking at inside of the A-frame.

NOTICE: The needle valve is used to hold and remove pressure from the hydraulic cylinder and should only be operated by hand. Never use tools to tighten or loosen the valve. Using excessive force in either direction on the needle valve will damage the pump unit.

INSTALL LOAD BAR ASSEMBLY

1. **Couple the tow vehicle and trailer.** Align and lower the trailer coupler onto the ball. The tow vehicle and the trailer need to be on the same level surface.
2. **Attach the load bars to the hydraulic cylinder.** Retrieve the load bar assembly. Remove the pin and bushings from the lower cylinder mount. Raise the trailer jack high enough that the load bar assembly can slide under it. Pin the hydraulic cylinder to the center hole in the lower cylinder mount using the removed pin and bushings, **see Figure F1.**

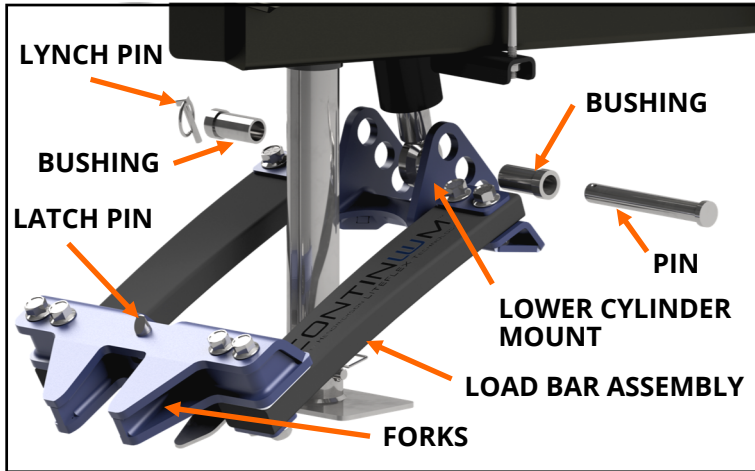

FIGURE F1: View of the load bar assembly under the trailer.

3. **Attach the load bar assembly to the spindle.** Open the needle valve on the hydraulic pump. Push down on the lower cylinder mount to extend the hydraulic cylinder until it is fully extended with about 5" of chrome rod showing. Lift the load bar assembly and slide it into the bottom of the spindle of the head unit until the latch pin of the forks engages with the spindle, **see Figure F2.** If the forks do not slide into the spindle far enough to engage the latch pin, then use the upper hole in the lower cylinder mount, **see Figure F2.** If the forks will still not slide into the spindle after trying a different mounting hole, call B&W Customer Service Department for support.

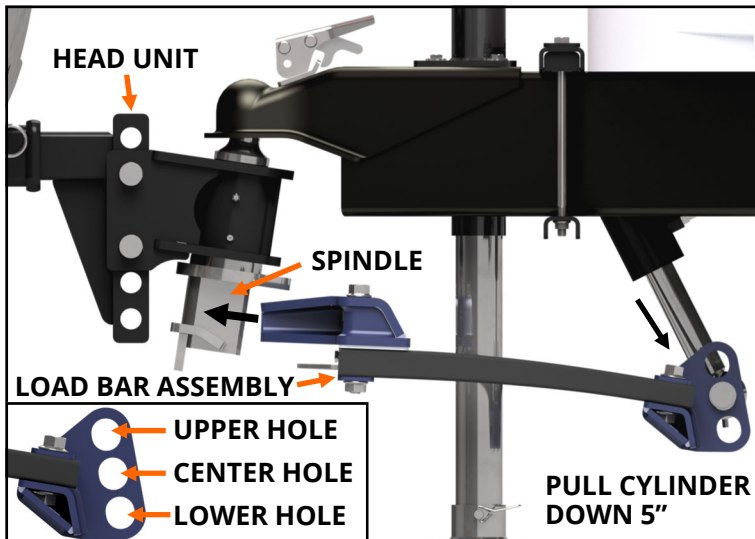

FIGURE F2: View of the driver side of the hitch.

INSTALL FORK HOLDER

NOTE: The fork holder bracket installation is optional. The fork holder is designed to provide a resting place for the front portion of the load bar assembly when the trailer is not hooked to a tow vehicle. If the trailer needs to be moved by a vehicle that is not equipped with the head assembly, the jack can be raised while the load bar assembly is resting on the bracket until the load bar assembly is constrained underneath the bottom of the trailer frame. **The fork holder bracket will only fit on trailer tongue jacks with a 2" diameter or smaller leg.**

1. **Install fork holder bracket.** Retrieve the fork holder bracket, 2" U-bolt, and two 3/8" nuts. Place the U-bolt around the jack stand leg and attach the fork holder bracket. Secure with the 3/8" nuts. The bracket must be aligned so it is in front of the tongue jack and above the jack foot, **See Figure G1.** Torque the 3/8" nuts to 30 ft.-lbs.

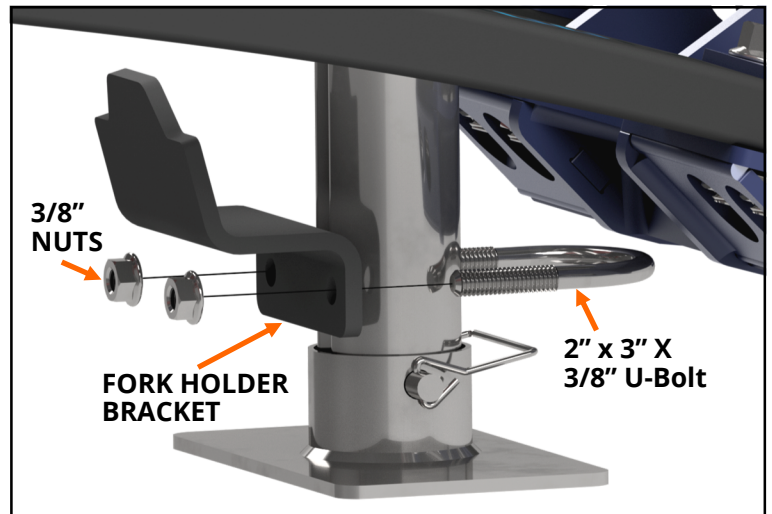

FIGURE G1: View of the jack foot under the trailer.

FINISH INSTALLATION

1. **Attach trailer connections.** Attach any wiring, break-away cables, and safety chains to the tow vehicle. If your chains are long enough, they may be passed down through load bar assembly and attached to the tow vehicle. No part of the chain should be tight against the load bar assembly.

ENGAGE WEIGHT DISTRIBUTION HITCH

IMPORTANT NOTES:

- The Continuum weight distribution hitch is designed to transfer part of a coupled trailer's weight from the tow vehicle's rear tires to its front tires.
- Due to the hydraulic cylinder of the Continuum hitch, the amount of weight that is transferred to the front tires is adjustable.
- Each towing configuration will require a different amount of pressure to be used.
- Some vehicle manufacturers provide a rating for how much of the weight should be moved to the front tires. The industry term for this rating is **Front Axle Load Restoration (FALR)** and is expressed as a percentage of the trailer load on the rear tires which is restored to the front.
- Check your vehicle's user manual for the recommended FALR.
- We advise using a minimum of 50% FALR and no more than 100% FALR if your tow vehicle does not have a recommended FALR.

Calculate cylinder load using the wheel well method. A practical method for determining the correct cylinder load is to use the front wheel well as a reference to observe the amount of weight which is returned to the front tires from the rear tires as the hydraulic pump is used to pressurize the cylinder, **use Figure H1 for Steps 1-3.**

1. **Measure wheel well uncoupled.** Move the tow vehicle and trailer so they are both on the same level surface. Before coupling, measure the distance from the ground to the top edge of the front wheel well. This distance will be referred to as **measurement A**.
2. **Chock trailer tires.** Always chock trailer tires before attempting to couple or uncouple the tow vehicle.
3. **Measure wheel well coupled.** Couple the trailer and tow vehicle, attach the load bar assembly to the head unit, then lift the jack foot off of the ground. Measure the distance from the ground to the top edge of the front wheel well. This distance will be referred to as **measurement B**.

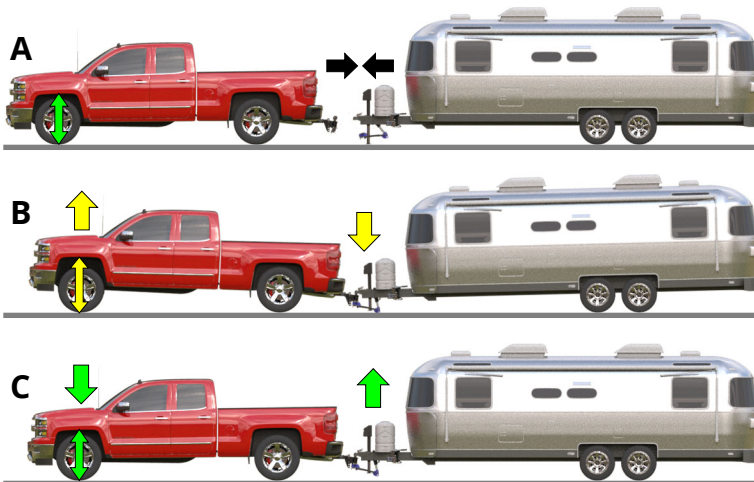

FIGURE H1: View of tow vehicle and trailer showing measurement locations.

4. **Restore wheel well height.** Returning the wheel well height to **measurement A** would represent a FALR of 100%. To calculate the distance the wheel well should move when using less than 100% FALR use the formula:

$$B - ((B - A) * FALR/100) = \text{Target measurement C}$$

Example:	Tow Vehicle:
Measurement A = 39"	Measurement A = _____
Measurement B = 40"	Measurement B = _____
FALR Required = 75%	FALR Required = _____
40" - 39" = 1"	_____ - _____ = _____
1" X 0.75 = 0.75"	_____ X _____ = _____
40 - 0.75 = 39.25"	_____ - _____ = _____

5. **Add pressure to the hydraulic cylinder.** Close the needle valve. Pull the pump handle out of the handle holder and push in then twist counter clockwise to extend it. Pump the handle of the hydraulic pump to restore load from the rear tires to the front tires, **see Figure H2.** Decrease the height of the front wheel well until it has been lowered to the target measurement.

NOTICE: If the target measurement cannot be reached before the cylinder rod is fully retracted and the cylinder bottoms out, then the cylinder will need to be secured to the lower hole in the lower cylinder mount.

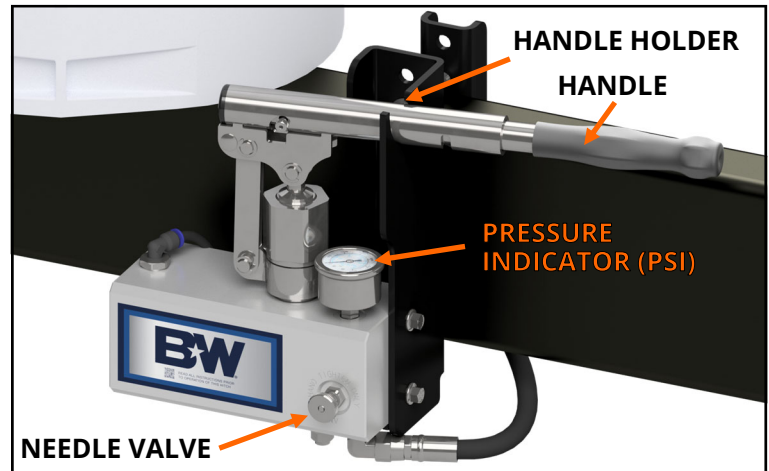

FIGURE H2: View of the driver side of A-frame

6. **Record the pressure reading.** Write down the reading on the pressure indicator for future reference. A log is provided on page 11 to keep track of the pressure.
7. **Return handle to holder.** Retract the handle and place it back in the handle holder. If moving the handle to the holder increased the pressure shown on the pressure indicator, use the needle valve to reduce the pressure back to the reading taken when the wheel well height was correct.

NOTE: The amount of pressure used will usually be around 1.2 times the tongue weight of the trailer with a FALR between 60% to 90%.

8. **Test setup inspection.** Perform an inspection of the tow set up. Double check that the trailer's connections to the tow vehicle are all secured.

UNCOUPLING PROCEDURE

NOTE: If the load bar assembly will be removed from the trailer, it has to be moved so the jack foot is no longer between the load bars before the foot is lowered to the ground.

1. **Chock trailer tires.** Always chock trailer tires before attempting to couple or uncouple the tow vehicle.
2. **Extend the hydraulic cylinder.** Open the needle valve on the hydraulic pump. Allow the cylinder to extend until the load bar assembly can be removed from the head unit. It may be necessary to push down on the lower cylinder mount to aid the lowering of the cylinder.
3. **Disconnect the load bar assembly.** Retract the latch pin by pulling up on the latch pin release lever, **as shown in Figure J1**. Pull the load bar assembly out of the head unit. Place the load bar into the fork holder bracket or use the safety chains to hold the load bar assembly.
4. **Lower the jack.** Lower the jack foot until it contacts the ground.

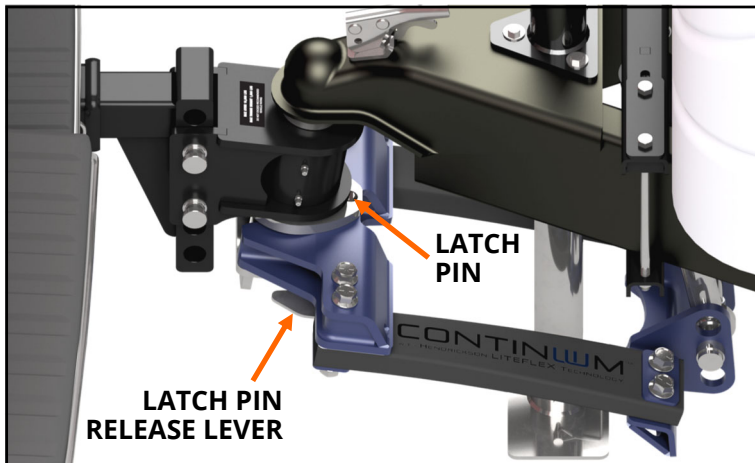

FIGURE J1: View of the driver side of A-frame.

LONG TERM STORAGE

When not in use, to extend the life of the product, the load bars and the head unit should not be left outside for extended periods of time. When preparing for long term storage, follow the procedure below.

- Open the needle valve on the hydraulic pump to relieve the cylinder pressure.
- Couple the trailer and raise the jack to remove the load bar assembly. Un-pin the load bar assembly from the hydraulic cylinder. Re-attach the pins and bushings to the load bar assembly.
- Uncouple the trailer and remove the head assembly.
- When not mounted on a trailer, the load bar and head unit must be kept in a storage area, out of the elements.
- Close the needle valve on the hydraulic pump, retract the cylinder by pumping the handle. Stop before the hydraulic system builds up any pressure.
- Place the handle back in the handle holder.

ROUTINE MAINTENANCE

Follow the maintenance procedures listed below before each trip & periodically as needed.

Before each trip:

- Check the hitch, vehicle receiver, trailer coupler, and trailer frame for physical damage. Look for metal deformation caused by hits, fractures in the welds, bent pins, and damage in places that experience heavy loads, including the receiver hitch or the ball coupler.
- Examine abrasion-prone regions for excessive wear or gouging.
- Inspect the hydraulic system for leaks (hose, pump, and cylinder).
- Check that all pins are present and are clipped.
- Check that all bolts are tight and no components are loose (*see note below*).
- Grease the head unit using the two grease fittings. *Recommended Grease: Multi-Purpose Lithium Complex Grease - NGLI Grade 2*

Periodically as needed:

- Spray white lithium grease onto the latching mechanism of the load bar assembly and the top of the forks.
- Spray white lithium grease onto the hydraulic pump handle.
- Spray white lithium grease onto the swivel ball end of the hydraulic cylinder.
- Lubricate and clean the pins and pin holes in the pin block.

NOTE: Observe the following torque specifications on hitch hardware (dry threads).

- The bolts on the load bar assembly were factory tightened to a specific torque and are not expected to come loose. If they do, torque the 1/2" hardware on the load bar assembly to 100 ft.-lbs.
- The 3/8" bolts should be torqued to 40 ft.-lbs.
- The 3/8" nuts attached to the U-bolt should be torqued to 30 ft.-lbs.
- The 3/4" bolt should be torqued to 150 ft.-lbs.

Load bar maintenance:

- The load bars are made of a composite and are vulnerable to damage by Phosphoric acid and Hydrofluoric acid which may be present in automotive cleaning agents. They are also used by many touchless car washes as part of a buffered cleaning solution. Repeated exposure to these chemicals may damage the bars.

CHANGING THE COUPLER BALL

It may be necessary to replace the coupler ball to change its size or if it has become damaged. Use the following steps and Figure K1 to replace the ball.

1. Remove the head unit from the tow vehicle.
2. Separate the ball mount and pin block by removing the two pins.
3. Loosen the set screw until the spindle can be removed from the socket (1/4" Allen wrench).
4. Remove the grease from the spindle and from inside the ball mount.
5. Remove the 1-1/4" nut and washer from the ball (1-7/8" deep well socket).
6. Replace the ball in the ball mount. The shank of the new ball must be 1-1/4". Use a new nut and lock washer to secure the ball.
7. Torque the nut to 415 ft.-lbs.
8. Insert the clean spindle back into the ball mount.
9. Tighten the set screw until it bottoms out. Test that the spindle cannot be pulled out of the ball mount.
10. Apply grease to the spindle and ball mount using the two grease fittings.

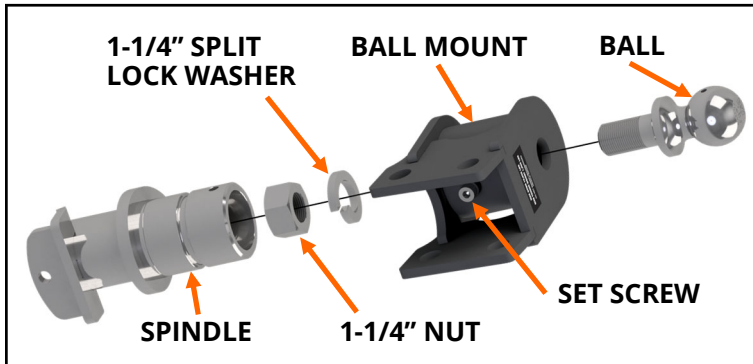

FIGURE K1: View of exploded ball mount.

⚠ WARNING: Changing the ball requires that the nut be torqued to a very high ft.-lbs. range. Without proper tools the ball cannot be safely changed. It may be necessary to use professional help. Failure to correctly torque the nut could lead to serious injury or death.

FREQUENTLY ASKED QUESTIONS

For more information, including a longer list of frequently asked questions, visit bwtrailerhitches.com

Q: Does the Continuum Weight Distribution Hitch have friction sway control?

A: Friction sway control is built-in to the hitch, and can lessen sway as much as the current leading brands. Sway control however, is much less important to towing stability than other considerations, such as: speed, road and weather conditions, trailer load distribution, tire conditions, and many other factors.

Q: What should be done if trailer sway is noticed during towing?

A: Towing stability, in a practical sense, is how fast the trailer can be towed before it becomes unstable and sway can occur. The more stable the set up is, the higher the speed the trailer can be towed. If sway occurs slow down and drive at a lower speed. These are factors that can adversely affect towing stability:

- Towing speed.
- Road & weather conditions.
- Trailer load distribution & tongue weight.
- Tire conditions & load rating.

Q: Can the trailer be backed up with the load bar assembly attached?

A: Yes, the Continuum hitch has a single point of attachment which gives it a large turning clearance.

Q: Is the Continuum hitch compatible with surge brakes?

A: Yes, but the majority of surge brake trailers include a central member in the tongue that prevents the hitch from being installed.

Q: Can the Continuum hitch be used with a tow vehicle that has an auto leveling system?

A: Yes, the auto leveling system will have to be turned off before coupling the trailer to the tow vehicle. Leave the auto leveling system off during setup and while using the Continuum hitch.



HYDRAULIC PSI LOG

DATE: _____

VEHICLE: _____

TRAILER: _____

FALR PERCENT: _____

PSI READING: _____

DATE: _____

VEHICLE: _____

TRAILER: _____

FALR PERCENT: _____

PSI READING: _____

DATE: _____

VEHICLE: _____

TRAILER: _____

FALR PERCENT: _____

PSI READING: _____

DATE: _____

VEHICLE: _____

TRAILER: _____

FALR PERCENT: _____

PSI READING: _____

DATE: _____

VEHICLE: _____

TRAILER: _____

FALR PERCENT: _____

PSI READING: _____

DATE: _____

VEHICLE: _____

TRAILER: _____

FALR PERCENT: _____

PSI READING: _____



AMERICAN MADE



BUILT TO LAST

SEE LIMITED LIFETIME WARRANTY AT
bwtrailerhitches.com/warranty



B&W TRAILER HITCHES
1216 HAWAII RD
P.O. BOX 186
HUMBOLDT, KS 66748

bwtrailerhitches.com